



**DL902HEU, DL1302HEU, DL1402VEEU,
DL1802VEU, DL1802VEEU Illustrated Parts Book**



DL Truck Loader Vacuum Illustrated Parts Book

DL902HEU, DL1302HEU, DL1402VEEU, DL1802VEU, DL1802VEEU

DL902HEU & DL1302HEU Hose and Boom

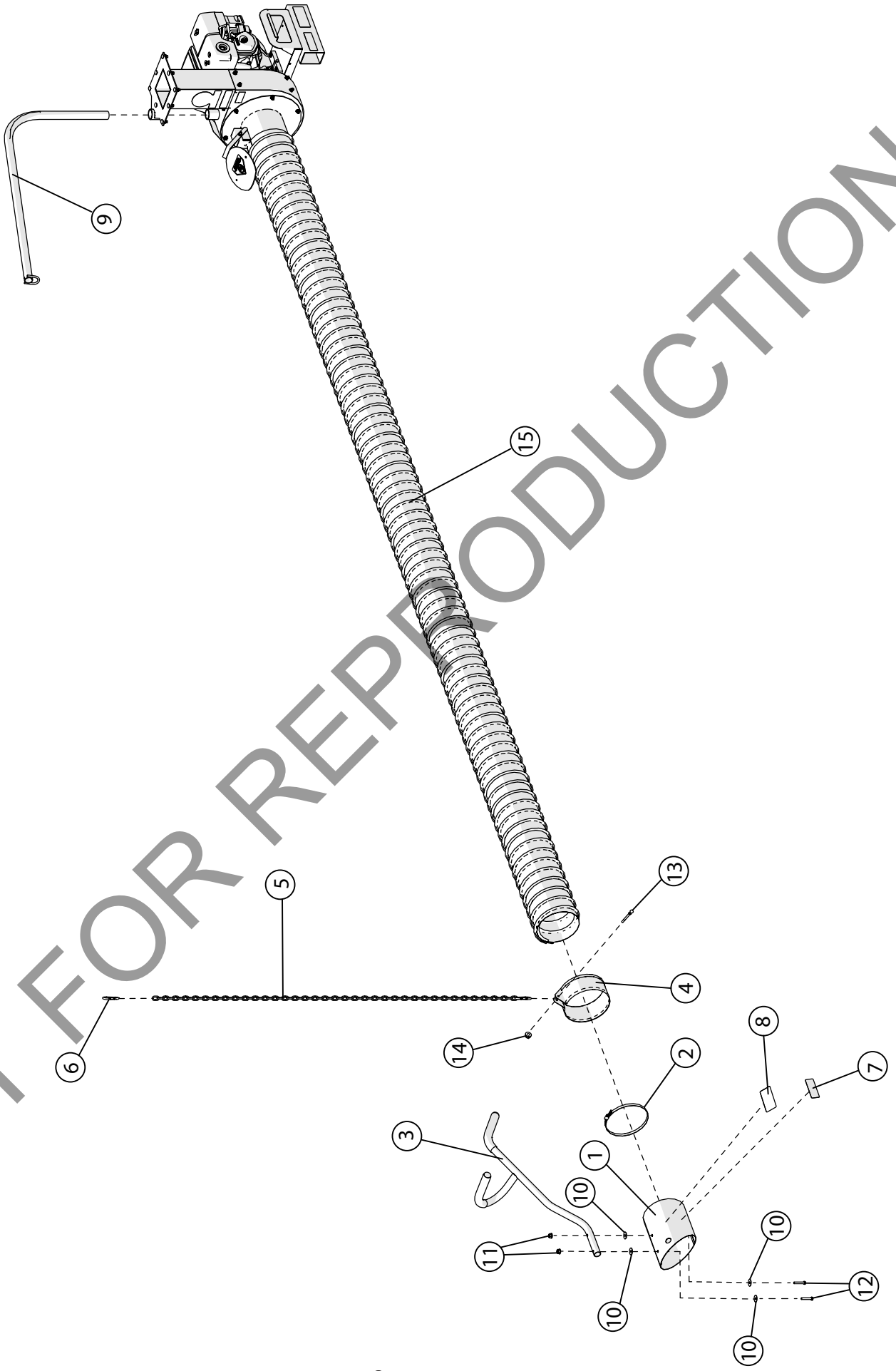

DL902HEU & DL1302HEU Hose and Boom

DL902HEU DL1302HEU

Item No.	Description	Part No.	Part No.	QTY
1	NOZZLE 8" STEEL FORMED	811007	811007	1
2	CLAMP HOSE 8" RAW	810566-01	810566-01	1
3	HANDLE NOZZLE/GRIP ASSY	791116	791116	1
4	BAND HOSE BOOM 8" FORMED	810880	810880	1
5	CHAIN 73 LINKS DL	791057	791057	1
6	HOOK, SNAP SAFETY 5/16" ZP	791027	791027	2
7	LABEL WARNING NOZZLE	790301	790301	1
8	LABEL WARNING ENGINE OVERHEAT	811215	811215	1
9	BOOM WA DL	812245	812245	1
10	WASHER FLAT FENDER 5/16	8172020	8172020	4
11	NUT-HEX-NYLK, FLG .3125"-18 ZP	8165002	8165002	2
12	SCREWCAP 5/16"-18 X 2" GR 5 HCS ZP	8041032	8041032	2
13	SCREWCAP 1/4"-20 X 2 3/4" HCS ZP	8041013	8041013	1
14	NUT-HEX-NYLK, FLG .250"-20 ZP	8165001	8165001	1
15	HOSE 8" X 16.5' IN CARTON	812390	-	1
	HOSE 8" INTAKE X 10'	-	811244	1
NOT SHOWN	STRAP, 1" X 60" ENDLESS RATCHET	792270	792270	1

DL1402VEEU, DL1802VEU & DL1802VEEU Hose and Boom

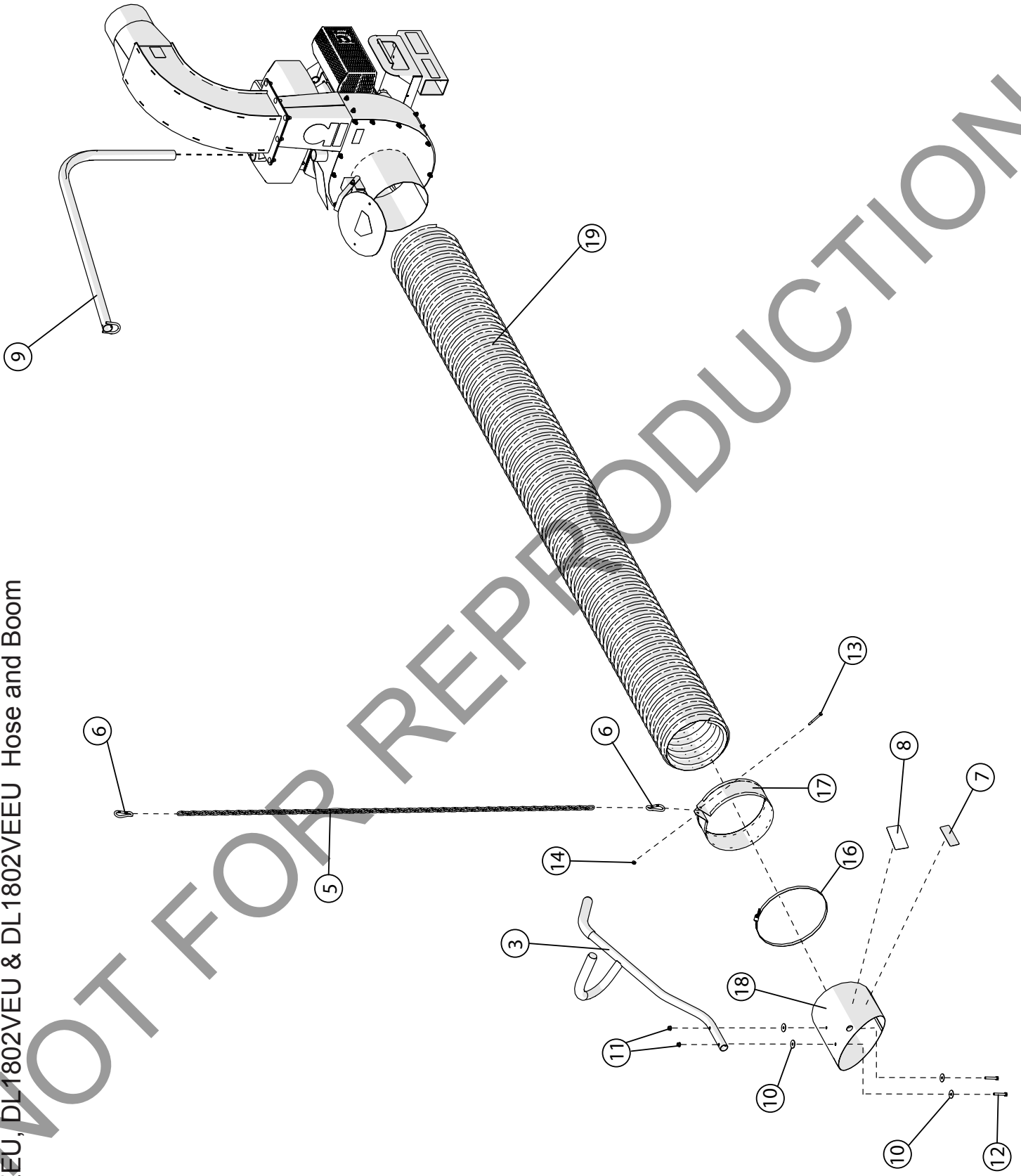

DL1402VEEU, DL1802VEU & DL1802VEEU Hose and Boom

DL1402VEEU
DL1802VEU
DL1802VEEU

Item No.	Description	Part No.	QTY
3	HANDLE NOZZLE/GRIP ASSY	791116	1
5	CHAIN 73 LINKS DL	791057	1
6	HOOK, SNAP SAFETY 5/16" ZP	791027	2
7	LABEL WARNING NOZZLE	790301	1
8	LABEL WARNING ENGINE OVERHEAT	811215	1
9	BOOM WA DL	812245	1
10	WASHER FLAT FENDER 5/16	8172020	4
11	NUT-HEX-NYLK, FLG .3125"-18 ZP	8165002	2
12	SCREWCAP 5/16"-18 X 2" GR 5 HCS ZP	8041032	2
13	SCREWCAP 1/4"-20 X 2 3/4" HCS ZP	8041013	1
14	NUT-HEX-NYLK, FLG .250"-20 ZP	8165001	1
16	CLAMP HOSE 10" RAW	810706-01	1
17	BAND HOSE BOOM 10" FORMED	810868	1
18	NOZZLE 10" STEEL FORMED	811005	1
19	HOSE INTAKE 10"X 10'	791033	1
NOT SHOWN	STRAP, 1" X 60" ENDLESS RATCHET	792270	1

DL902HEU & DL1302HEU Impeller

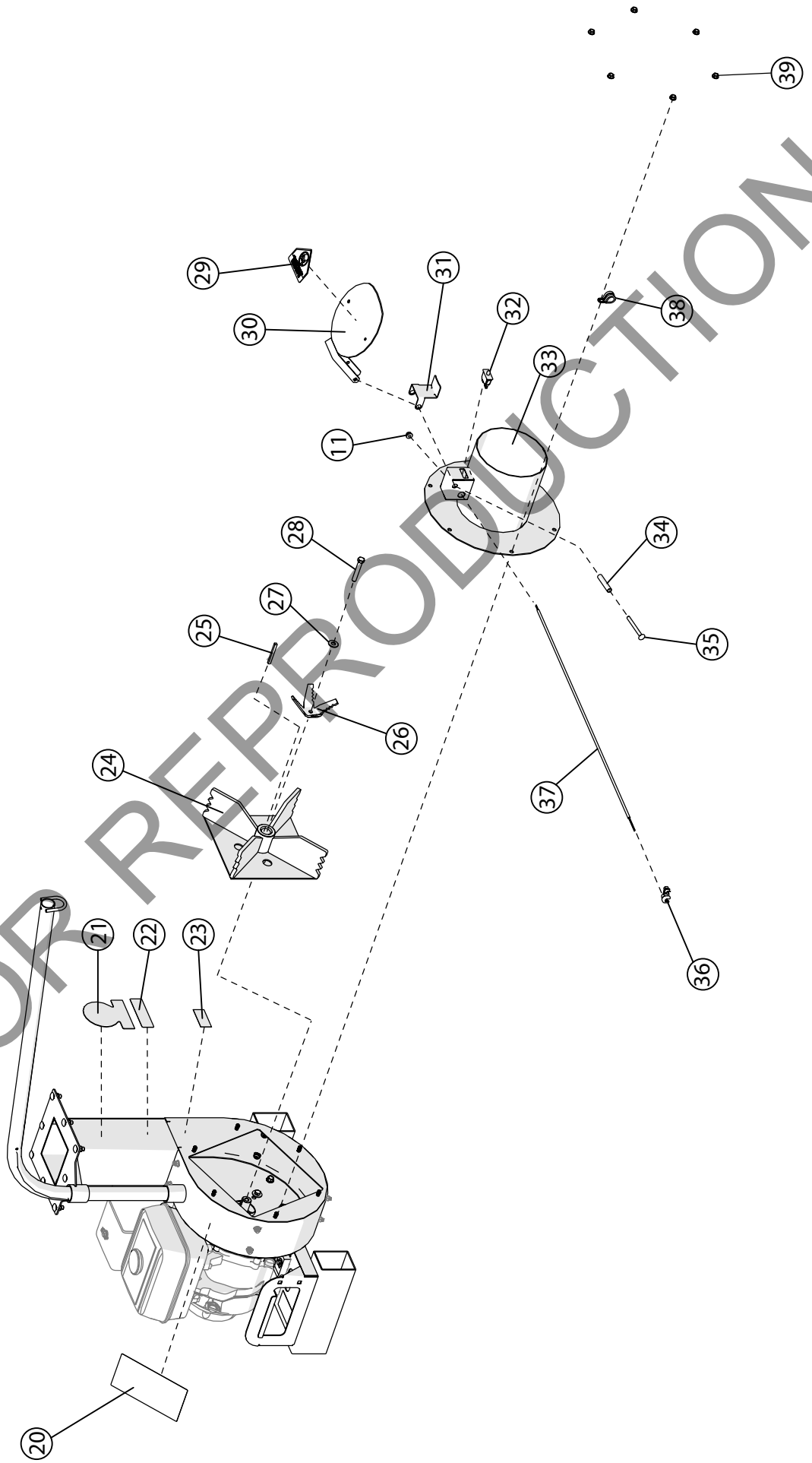

DL902HEU & DL1302HEU Impeller

DL902HEU DL1302HEU

Item No.	Description	Part No.	Part No.	QTY
11	NUT-HEX-NYLK, FLG .3125"-18 ZP	8165002	8165002	1
20	LABEL DL INSTRUCTION/WARN	790142	790142	1
21	LABEL LOGO DL12/13/18	812213	812213	1
22	LABEL DL PIRANHA	100283	100283	1
23	LABEL, WARNING LINER DL	100330	100330	1
24	IMPELLER WA DL12/13	812256	812256	1
25	KEY 1/4" SQ X 2 3/4"	9201125	9201125	1
26	DEBRIS REDUCER DL12/13/18	812283	812283	1
27	WSHR-STL, BLV, .450" X 1.063" X .082" MZ	8181016	-	1
	WSHR-STL, BLV, .386" X 1.063" X .082" MZ	-	8181012	1
28	SCREWCAP 7/16"-20 x 2 3/4"GR.8 W/PATCH	440285	790167	1
29	LABEL WARNING OPEI	400424	400424	1
30	FLAPPER WA 8"	812230	812230	1
31	LEVER HOSE SWITCH	791068	791068	1
32	SWITCH, SAFETY INTERLOCK	791095	791095	1
33	PLATE FRONT WA DL12/13	812227	812227	1
34	SPACER 3/8" X 2 1/2"	900503	900503	1
35	BOLT CARRIAGE 5/16-18 X 3 1/2" ZP	8024050	8024050	1
36	STRAIN RELIEF HEYCO 1244	500282	500282	1
37	HARNES WIRE DL 12/13/18 KILL SWITCH	812309	812309	1
38	CLAMP ROUTING FUEL LINE	791070	791070	1
39	NUT 5/16"-18 SER. HEX WSHR FLNG ZP	350346	350346	6

DL1402VEEU, DL1802VEU & DL1802VEEU Impeller

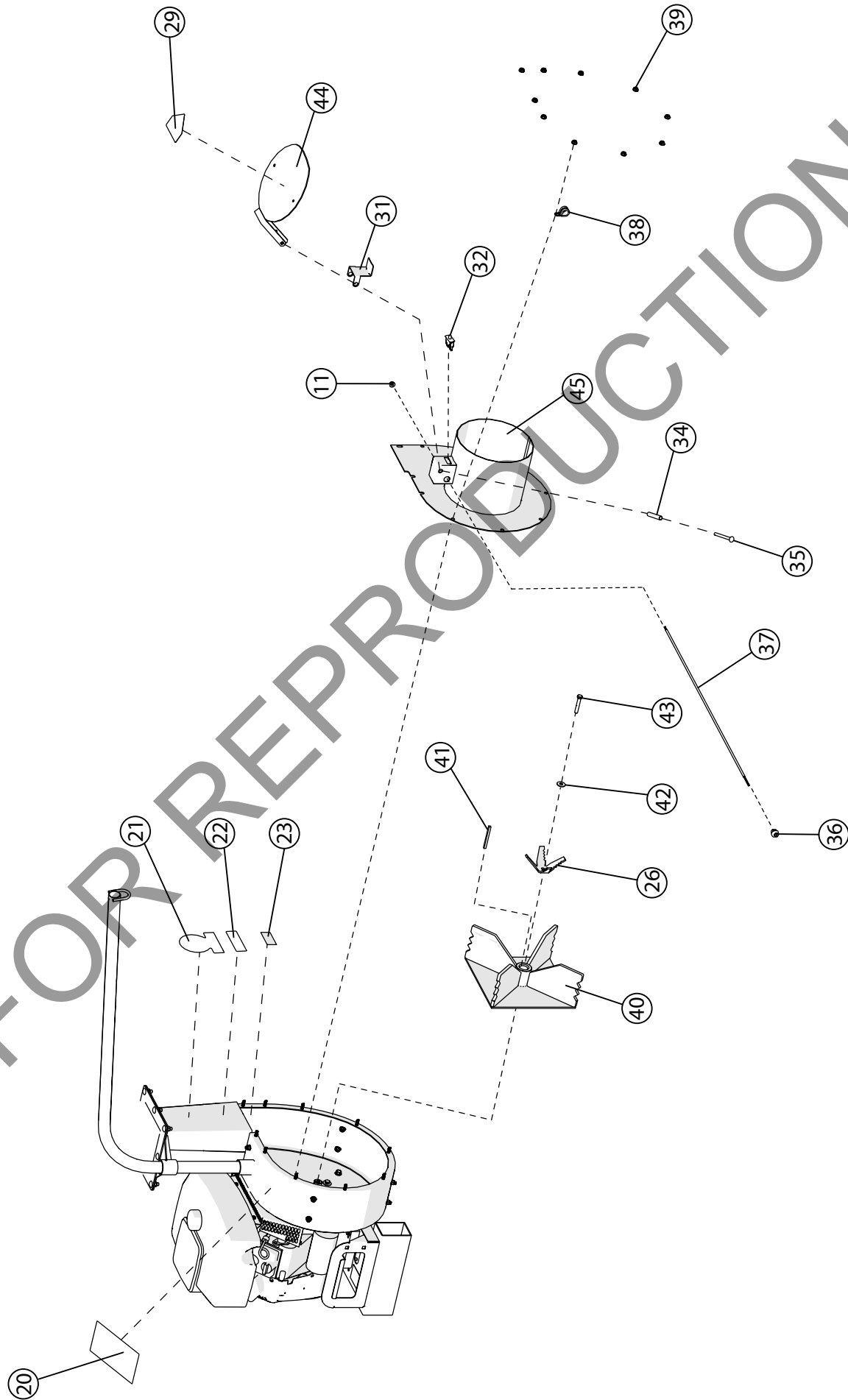

DL1402VEEU, DL1802VEU & DL1802VEEU Impeller

DL1402VEEU DL1802VEU
DL1802VEEU

Item No.	Description	Part No.	Part No.	QTY
11	NUT-HEX-NYLK, FLG .3125"-18 ZP	8165002	8165002	1
20	LABEL DL INSTRUCTION/WARN	790142	790142	1
21	LABEL LOGO DL12/13/18	812213	812213	1
22	LABEL DL PIRANHA	100283	100283	1
23	LABEL, WARNING LINER DL	100330	100330	1
26	DEBRIS REDUCER DL12/13/18	812283	812283	1
29	LABEL WARNING OPEI	400424	400424	1
31	LEVER HOSE SWITCH	791068	791068	1
32	SWITCH, SAFETY INTERLOCK	791095	791095	1
34	SPACER 3/8" X 2 1/2"	900503	900503	1
35	BOLT CARRIAGE 5/16-18 X 3 1/2" ZP	8024050	8024050	1
36	STRAIN RELIEF HEYCO 1244	500282	500282	1
37	HARNESS WIRE DL 12/13/18 KILL SWITCH	812309	812309	1
38	CLAMP ROUTING FUEL LINE	791070	791070	1
39	NUT 5/16"-18 SER. HEX WSHR FLNG ZP	350346	350346	10
40	IMPELLER WA 16"	810695	810695	1
41	KEY 1/4" SQ X 3 1/4"	9201128	9201128	1
42	WSHR-STL, BLV, .450" X 1.063" X .082" MZ	8181016	-	1
	WSHR-STL, BLV, .386" X 1.063" X .082" MZ	-	8181012	1
43	SCREWCAP 3/8-24 X 2 1/4" GR 8 ZP W/ PATCH	-	810932	1
	SCR-CAP, HEX .4375"-20X3.25" EP42 G8 YZ	813205	-	1
44	FLAPPER WA 10"	791102	791102	1
45	PLATE FRONT WA DL18	812225	812225	1

DL902HEU & DL1302HEU Housing to Engine Hub Connection

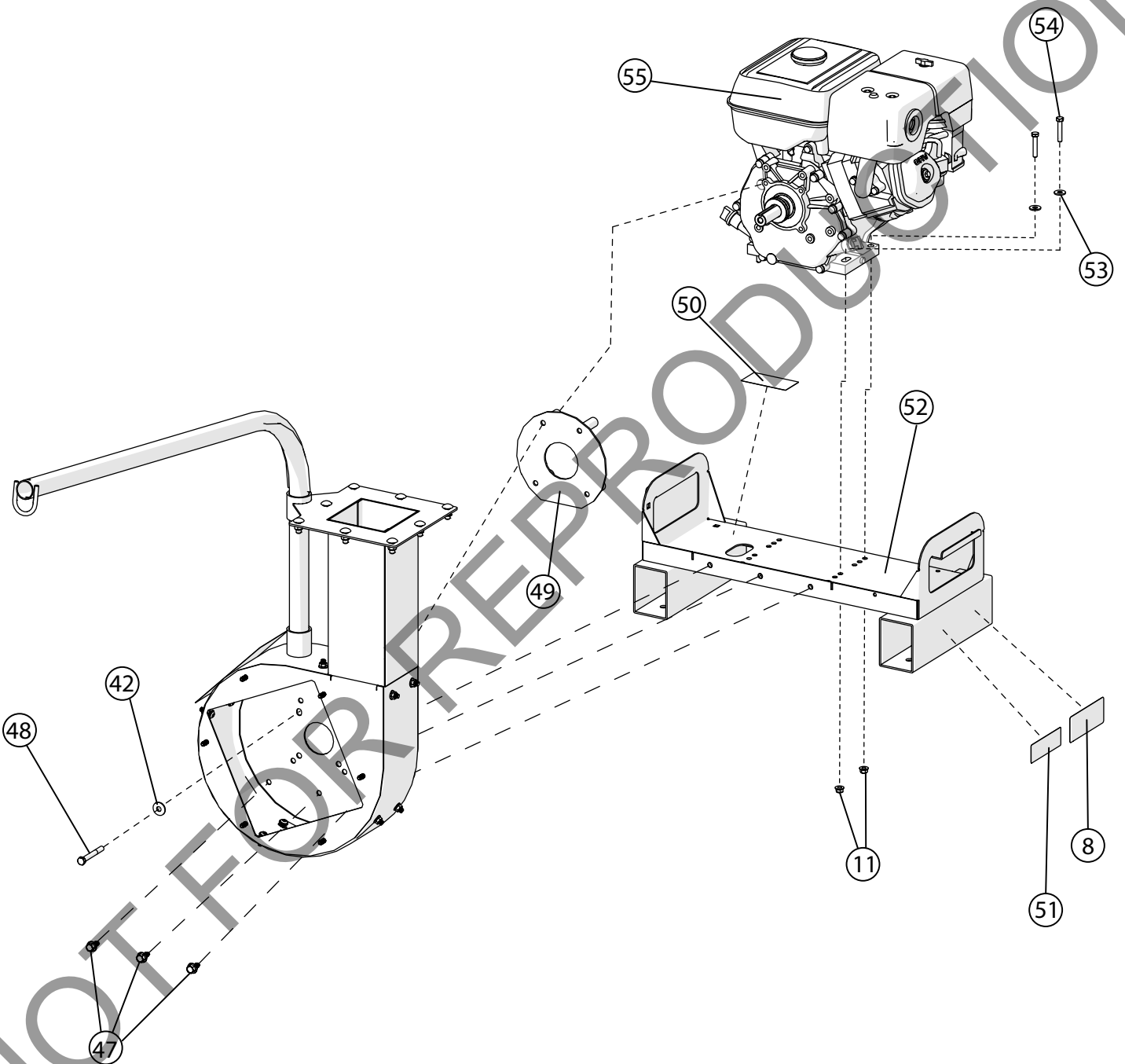

DL902HEU & DL1302HEU Housing to Engine Hub Connection

DL902HEU DL1302HEU

Item No.	Description	Part No.	Part No.	QTY
8	LABEL WARNING ENGINE OVERHEAT	811215	811215	1
11	NUT-HEX-NYLK, FLG .3125"-18 ZP	8165002	8165002	4
42	WSHR-STL, BLV, .386" X 1.063" X .082" MZ	8181012	8181012	4
47	SER. HEX WSHR FLNG SCR 0.375 - 16 x 0.75	791080	791080	3
48	SCREWCAP 3/8"-16 X 3" HCS ZP	8041058	8041058	4
49	SPACER ENGINE WA DL12/13/14	812235	812235	1
50	LABEL WARNING SECURE	790232	790232	1
51	LABEL SPARK ARRESTOR EN/SP	100256	100256	1
52	FRAME ASSY DL12/13/18 W/LABELS SERVICE	812100-S	812100-S	1
53	WASHER 5/16 FLAT ZP	8171003	8171003	4
54	SCREWCAP 5/16"-18 X 1 3/4" GR 5 HCS ZP	8041031	8041031	4
55	ENGINE 9 HP HONDA GX270UT2 QA2	430387	-	1
	ENGINE 13 HP HONDA GX390UT2 QA2	-	430366	1

DL1402VEEU, DL1802VEU & DL1802VEEU Housing
to Engine Hub Connection

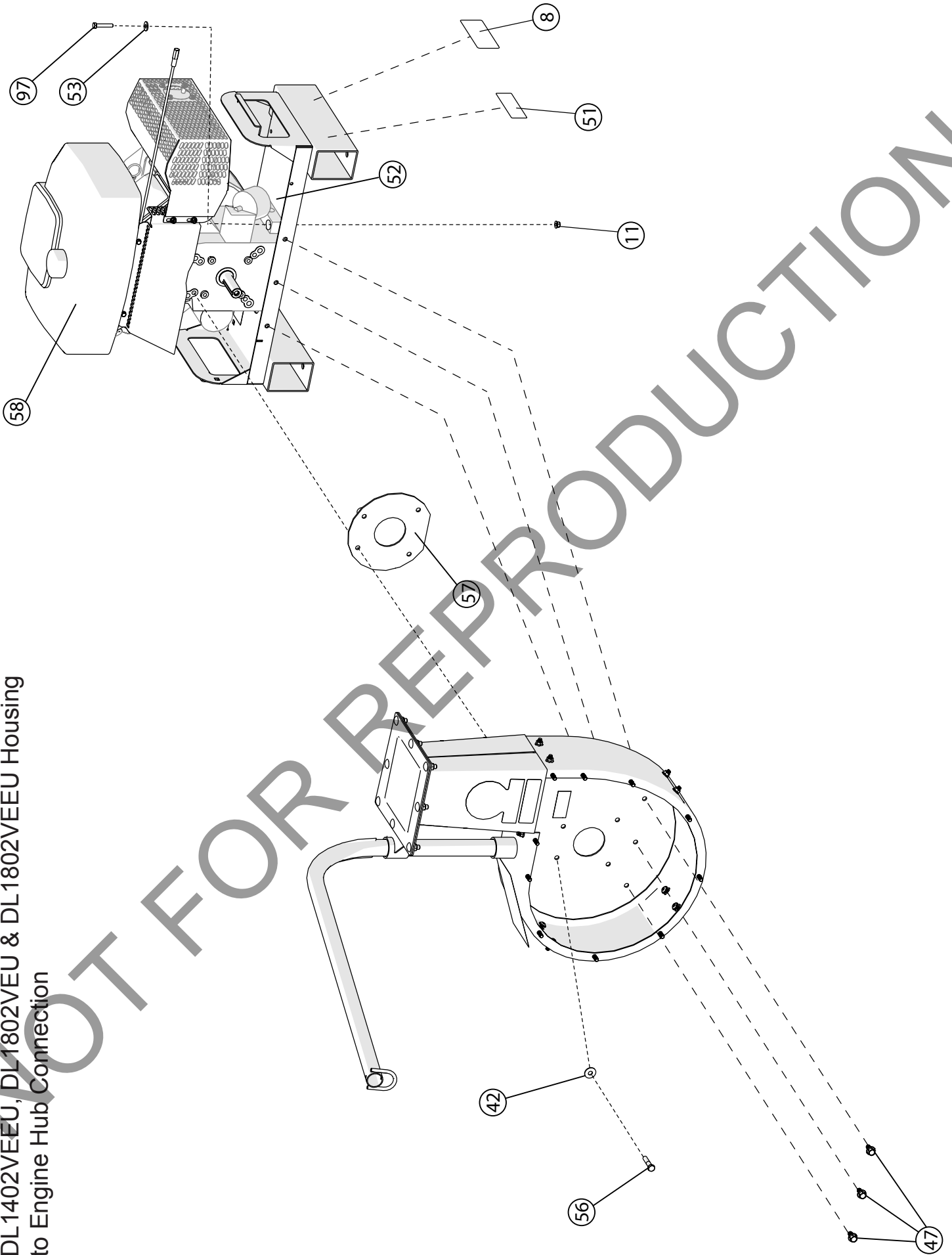

DL1402VEEU, DL1802VEU & DL1802VEEU Housing to Engine Hub Connection

DL1402VEEU

DL1802VEU DL1802VEEU

Item No.	Description	Part No.	QTY	Part No.	Part No.	QTY
8	LABEL WARNING ENGINE OVER-HEAT	811215	1	811215	811215	1
11	NUT-HEX-NYLK, FLG .3125"-18 ZP	8165002	4	8165002	8165002	4
42	WSHR-STL, BLV, .386" X 1.063" X .082" MZ	8181012	4	8181012	8181012	4
47	SER. HEX WSHR FLNG SCR 0.375 - 16 x 0.75	791080	3	791080	791080	3
51	LABEL SPARK ARRESTOR EN/SP	100256	1	100256	100256	1
52	FRAME ASSY DL12/13/18 W/LABELS SERVICE	812100-S	1	812100-S	812100-S	1
53	WASHER 5/16 FLAT ZP	8171003	4	8171003	8171003	4
56	SCREWCAP 3/8"-16 X 3" HCS ZP	8041058	4	-	-	4
	SCREWCAP 3/8"-16 X 1 3/4" HCS ZP	-	4	8041053	8041053	4
57	SPACER ENGINE WA DL12/13/14	812235	1	-	-	1
	SPACER ENGINE WA DL18	-	1	812238	812238	1
58	ENGINE, VANGUARD 400 E/S	813204	1	-	-	1
	ENGINE 18 HP VANGUARD HIGH EXHAUST	-	1	812240	-	1
	ENGINE 18 HP VN HIGH EXHAUST ELECTRIC	-	1	-	812241	1
97	SCREWCAP 5/16"-18 X 2" GR 5 HCS ZP	-	-	8041032	8041032	2
	SCREWCAP 5/16"-18 X 1 3/4" GR 5 HCS ZP	8041031	4	8041031	8041031	2

DL1802VEU & DL1802VEEU Engine Hub

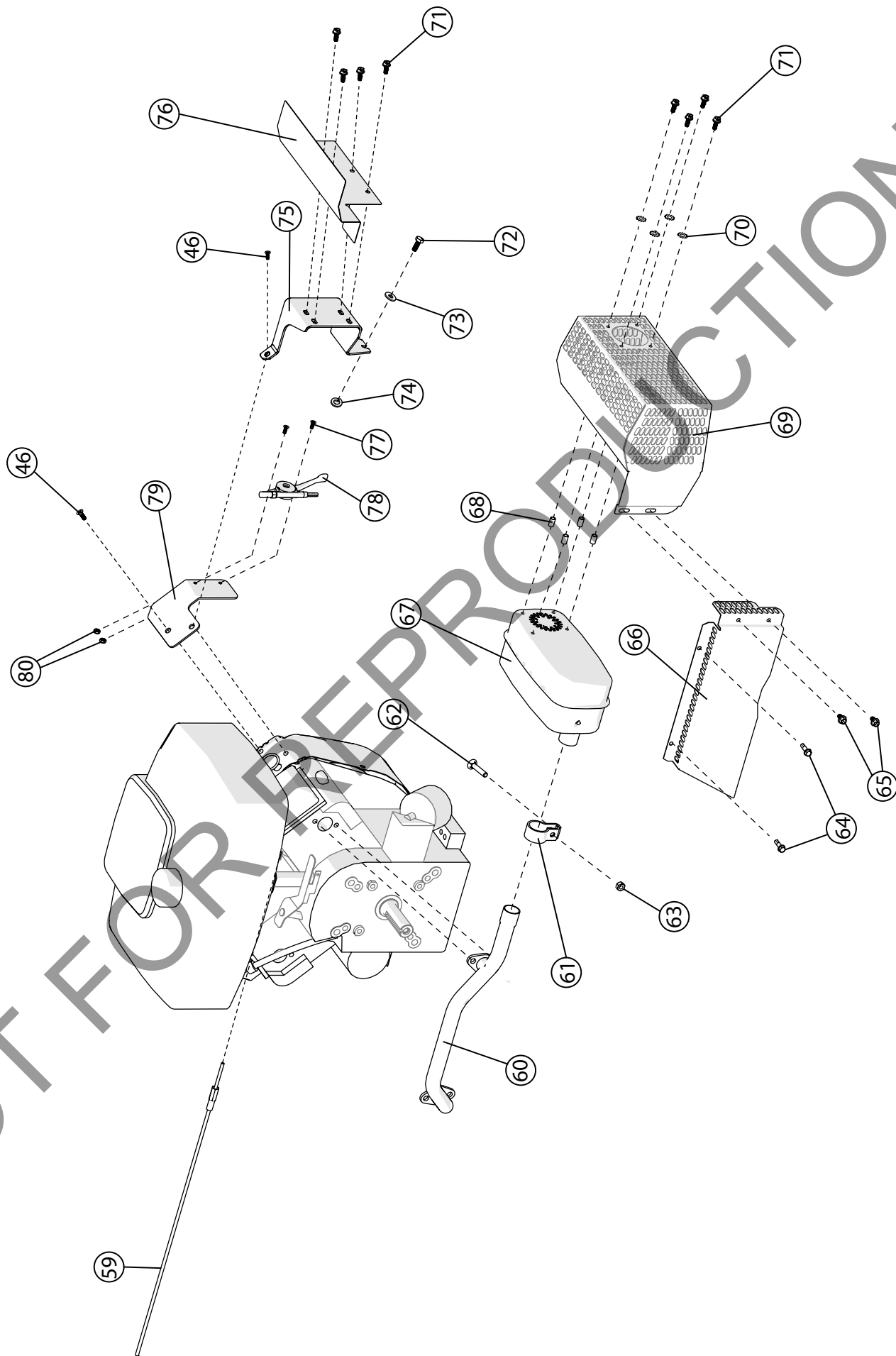

DL1802VEU & DL1802VEEU Engine Hub

DL1802VEU
DL1802VEEU

Item No.	Description	Part No.	QTY
46	REF	REF	2
59	CABLE THROTTLE DL18	812281	1
60	REF	REF	1
61	MUFFLER CLAMP VN	812240-4	1
62	BOLT CARRIAGE 5/16-18 X 1 3/4" ZP	8024043	1
63	NUT 5/16-18 HEX ZP	8142002	1
64	SCREW SM 1/4" X 1" DRILL PT.	430208	2
65	BOLT 1/4-20 x 1/2 SER FLANGE	812381	2
66	GUARD MANIFOLD DL	812243	1
67	MUFFLER 18 HP VN	812240-1	1
68	SPACER CONTROL LIFT	850198	4
69	GUARD, MUFFLER DL18 SW	812410	1
70	WASHER LOCK 1/4 EXTERNAL TOOTH	8181007	4
71	SCREW SELF TAP 1/4"-20 X 5/8" HWH TYPE F	890359	8
72	SCREWCAP M6 x 16 ZP	812240-6	1
73	WASHER M6 FLAT ZP	812240-5	1
74	WASHER LOCK M6 ZP	812240-7	1
75	MUFFLER MOUNT BRACKET VN	812240-3	1
76	MUFFLER HEAT SHIELD VN	812240-2	1
77	SCREW MACHINE FLAT HD PHIL #10-24	830514	2
78	CONTROL THROTTLE	440013	1
79	BRACKET MOUNT THROTTLE CONTROL	812280	1
80	NUT LOCK LT #10-24 HEX	8164005	2

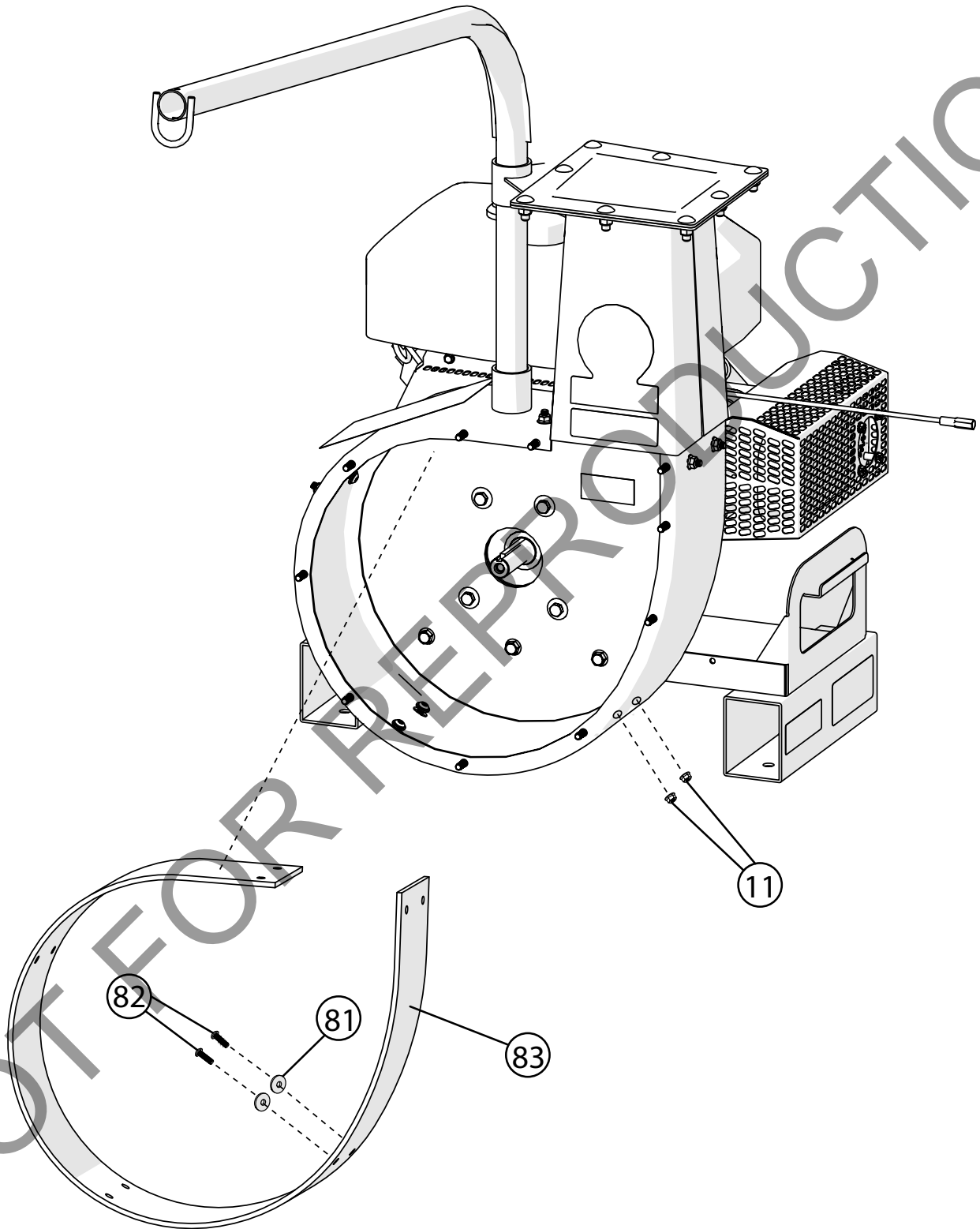

DL902HEU, DL1302HEU, DL1402VEEU, DL1802VEU & DL1802VEEU Liner

DL902HEU
DL1302HEU

DL1402VEEU
DL1802VEU
DL1802VEEU

Item No.	Description		Part No.	QTY
11	NUT-HEX-NYLK, FLG .3125"-18 ZP	8165002	8165002	10
81	WASHER 5/16 SAE Z/P	8172008	8172008	10
82	SCREW BUTTON HEAD 5/16"-18 X 1.00	791151	791151	10
83	Verschleißeinlage DL13 inkl. Schrauben u. Muttern	812394	-	1
	Verschleißeinlage DL 18 inkl. Schrauben u. Muttern	-	812391	1

NOT FOR REPRODUCTION

Housing and Liner Kit w/Labels

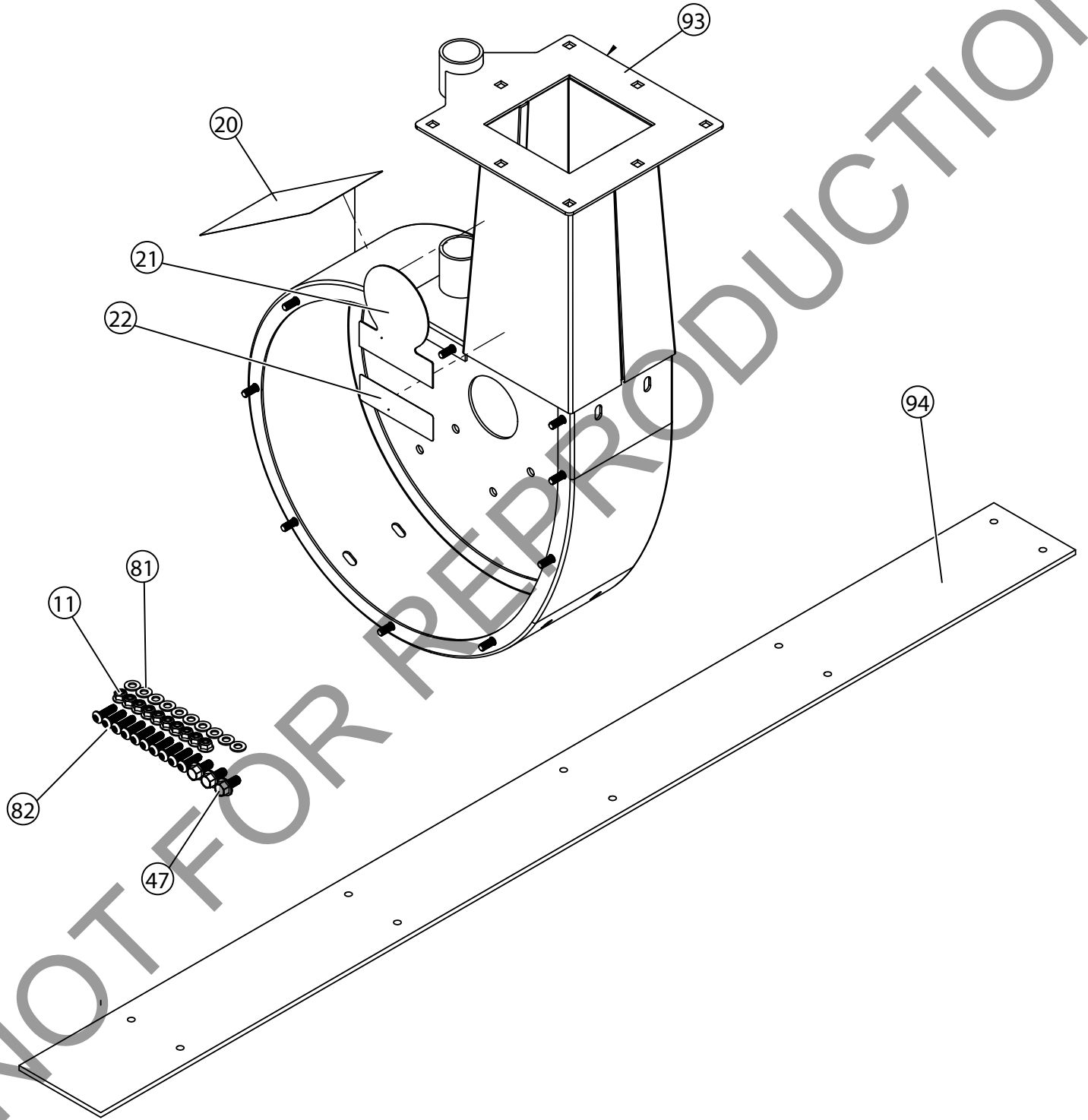

Housing and Liner Kit w/Labels

KIT P/N 813601		FITS: DL9-13	
Item No.	Description	Part No.	QTY
11	NUT-HEX-NYLK, FLG .3125"-18 ZP	8165002	10
20	LABEL DL INSTRUCTION/WARN	790142	1
21	LABEL LOGO DL12/13/18	812213	1
22	LABEL DL PIRANHA	100283	1
47	SER. HEX WSHR FLNG SCR 0.375 - 16 x 0.75	791080	3
81	WASHER 5/16 SAE Z/P	8172008	10
82	SCREW BUTTON HEAD 5/16"-18 X 1.00	791151	10
93	WA, HOUSING DL902/1302	813100	1
94	LINER PLASTIC DL13	812394	1

KIT P/N 813602		FITS: DL14-18	
Item No.	Description	Part No.	QTY
11	NUT-HEX-NYLK, FLG .3125"-18 ZP	8165002	10
20	LABEL DL INSTRUCTION/WARN	790142	1
21	LABEL LOGO DL12/13/18	812213	1
22	LABEL DL PIRANHA	100283	1
47	SER. HEX WSHR FLNG SCR 0.375 - 16 x 0.75	791080	3
81	WASHER 5/16 SAE Z/P	8172008	10
82	SCREW BUTTON HEAD 5/16"-18 X 1.00	791151	10
93	WA, HOUSING DL1402/1802	813101	1
94	LINER (5" W) DL18 (PLASTIC)	812391	1

DL902HEU, DL1302HEU, DL1402VEEU, DL1802VEU & DL1802VEEU
Elbow to Housing Connection

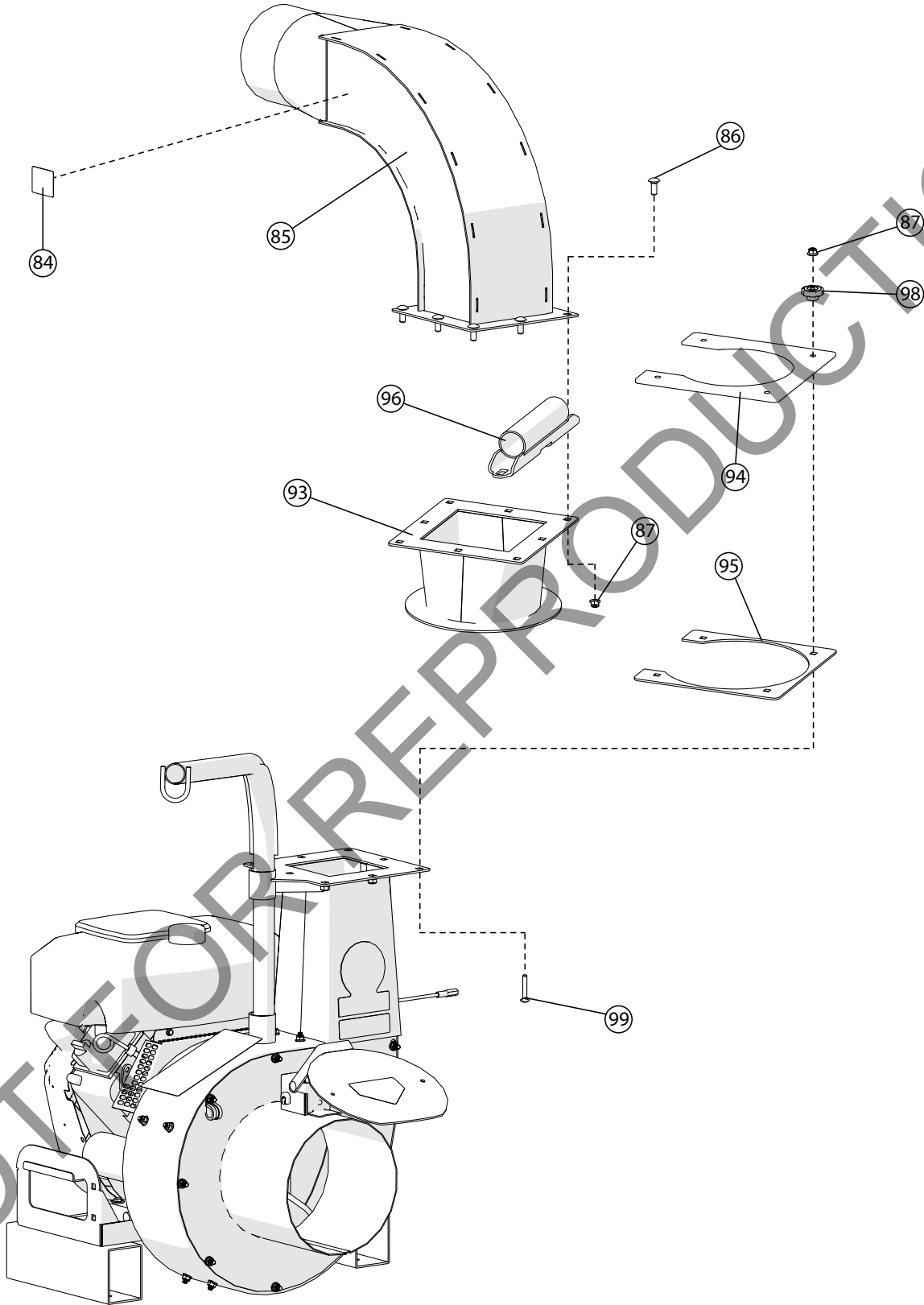

DL902HEU, DL1302HEU, DL1402VEEU, DL1802VEU & DL1802VEEU
 Elbow to Housing Connection

DL902HEU
 DL1302HEU
 DL1402VEEU
 DL1802VEU
 DL1802VEEU

Item No.	Description	Part No.	QTY
84	LABEL DANGER FLYING DEBRIS	810736	1
85	WA, ELBOW, 6" SQUARE, SQUARE FLANGE	812119	1
86	BLT-RDHDSSQNK, .375"-16 X 1.000 G5 ZP	8024058	12
87	NUT-HEX-NYLK, FLG .375"-16 ZP	8165003	16
93	WA, ROTATION ADAPTER, SML FRM DL	813102	1
94	PLATE, CLAMP, TOP SML DL PAINTED	813404	1
95	PLATE, CLAMP, BOTTOM SML DL PAINTED	813405	1
96	WA, ELBOW ROTATION ASSIST	792122	1
98	KNOB 3/8-18, SOLID HUB	811230	4
99	BLT-RDHDSQNK, .375"-16 X 2.500" G5 ZP	8024069	4

NOT FOR REPRODUCTION

DL1402VEEU Battery Bracket

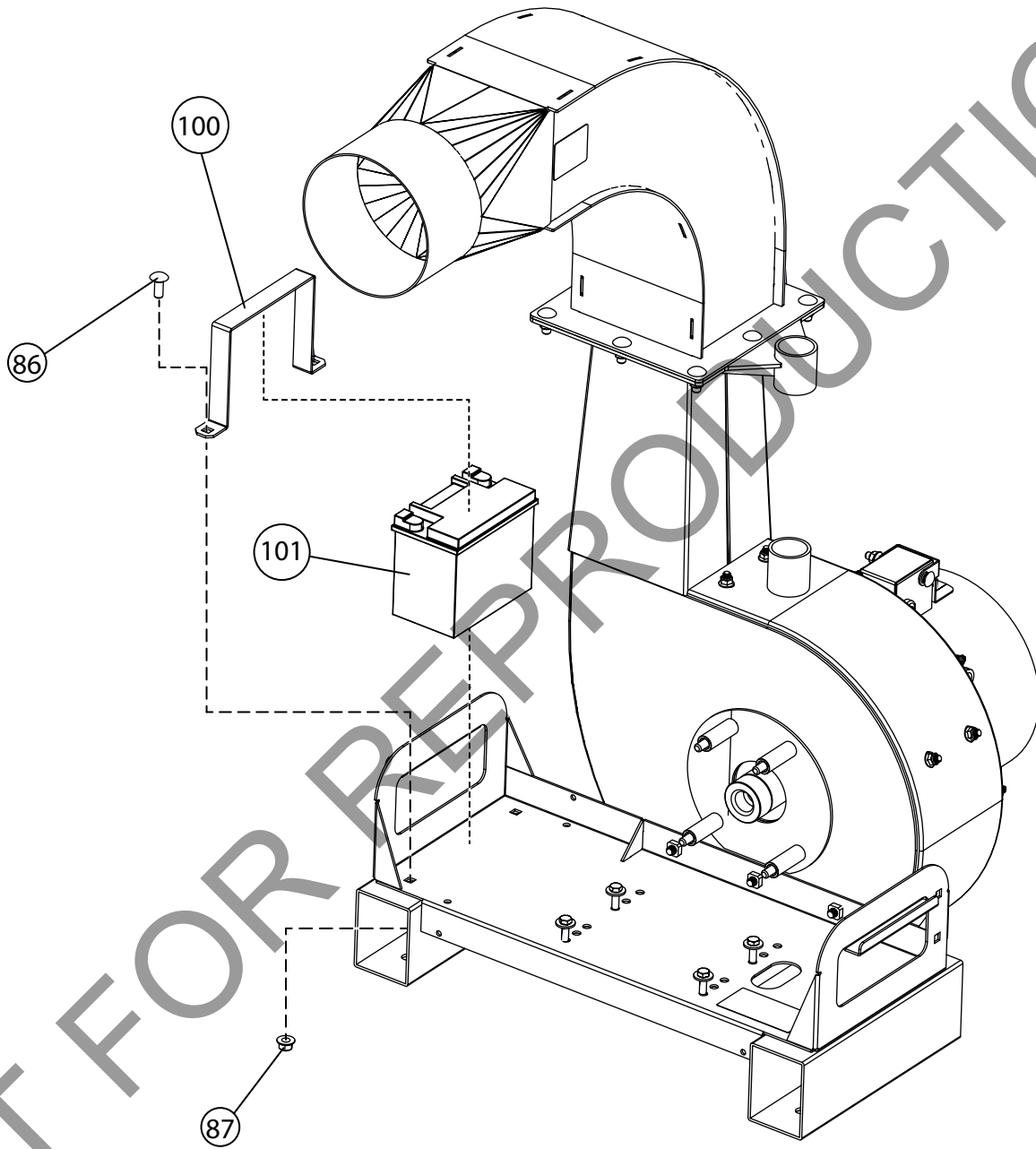

DL1402VEEU Battery Bracket

DL1402VEEU

Item No.	Description	Part No.	QTY
86	BLT-RDHDSSQNK, .375"-16 X 1.000 G5 ZP	8024058	4
87	NUT-HEX-NYLK, FLG .375"-16 ZP	8165003	4
100	BRACKET BATTERY STRAP DL14SE	812372	1
101	BATTERY 10AH/12 VOLT	812371	
NOT SHOWN	CABLE BATTERY RED 36"	812282	1
NOT SHOWN	CABLE BATTERY BLACK 20"	812341	1

NOT FOR REPRODUCTION

DL1802VEEU Battery Bracket to Housing Connection

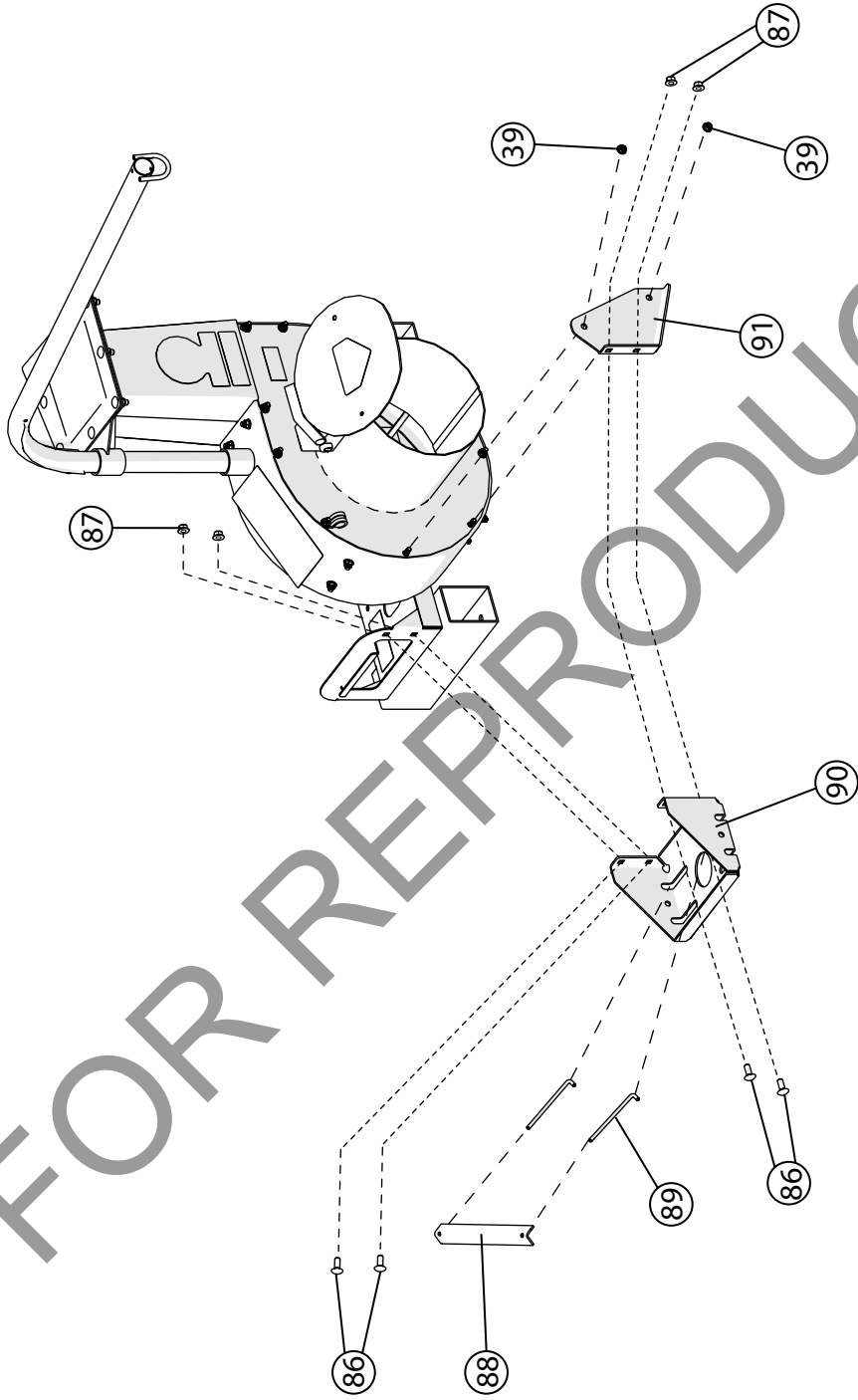

DL1802VEEU Battery Bracket to Housing Connection

DL1802VEEU

Item No.	Description	Part No.	QTY
39	NUT 5/16"-18 SER. HEX WSHR FLNG ZP	350346	2
86	BLT-RDHDSSQNK, .375"-16 X 1.000 G5 ZP	8024058	4
87	NUT-HEX-NYLK, FLG .375"-16 ZP	8165003	4
88	BRACKET BATTERY DL	790230	1
89	ROD BATTERY HOLD DOWN 6"	812396	2
90	TRAY BATTERY DL18	812299	1
91	BRACKET MOUNT TRAY BATTERY DL18	812395	1
92	ROD BATTERY HOLD DOWN	790231	2
NOT SHOWN	BATTERY CABLE POSITIVE BC2600	501222	1
NOT SHOWN	CABLE BATTERY BLACK 16"	790133	1

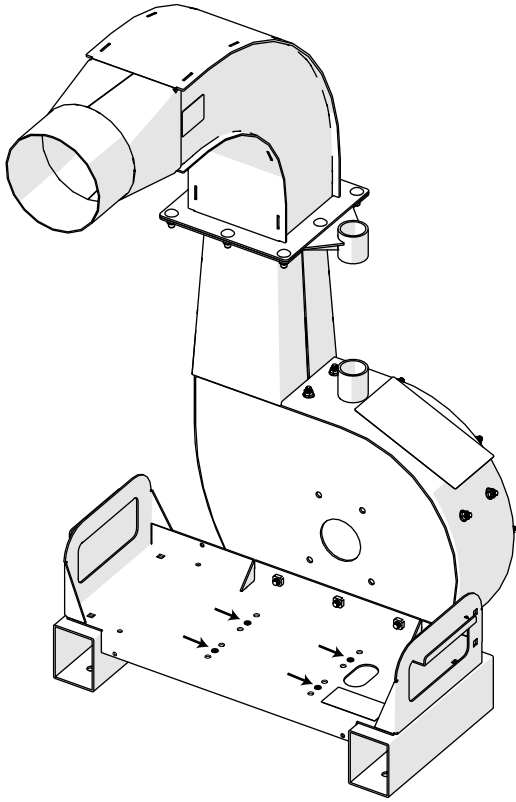

DL902HEU
Engine Mounting Points

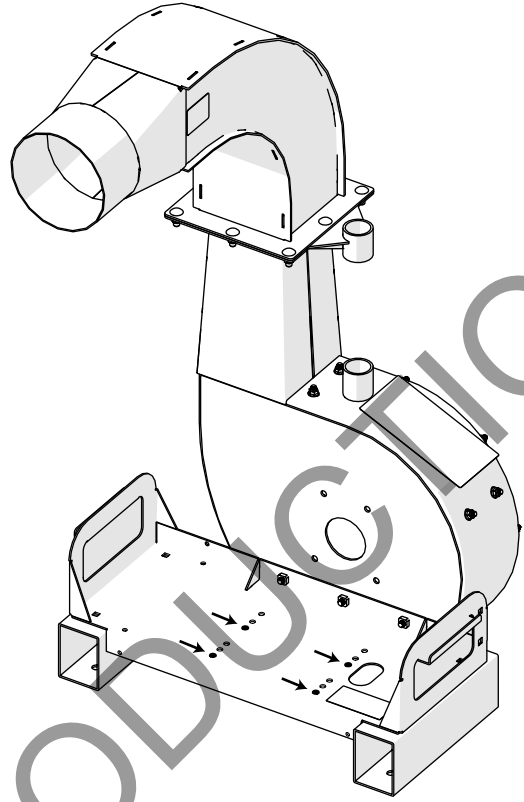

DL1302HEU & DL1402VEEU
Engine Mounting Points

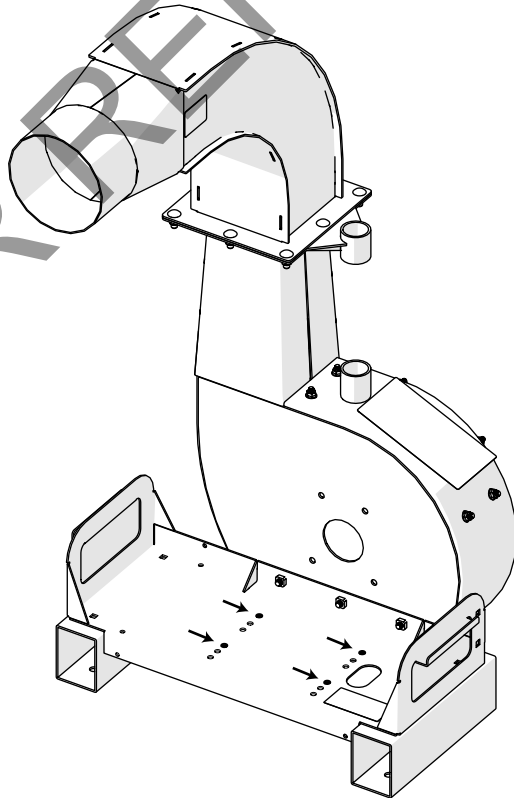

DL1802VEU & DL1802VEEU
Engine Mounting Points

DL9-13 Wiring Diagram

Engine Stop Switch

	EXT (+)	EXT (-)
OFF		
ON		

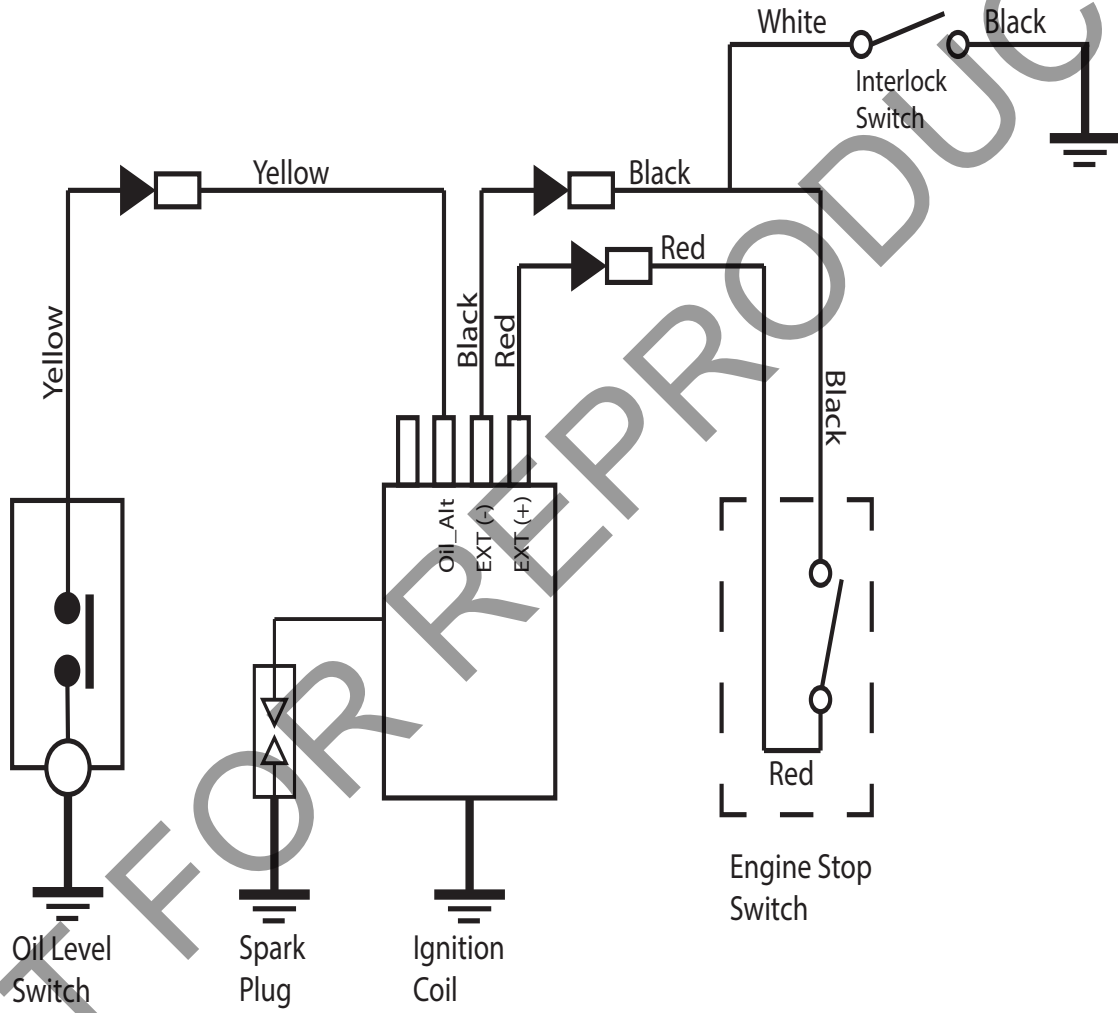

DL1402VEEU Wiring Diagram

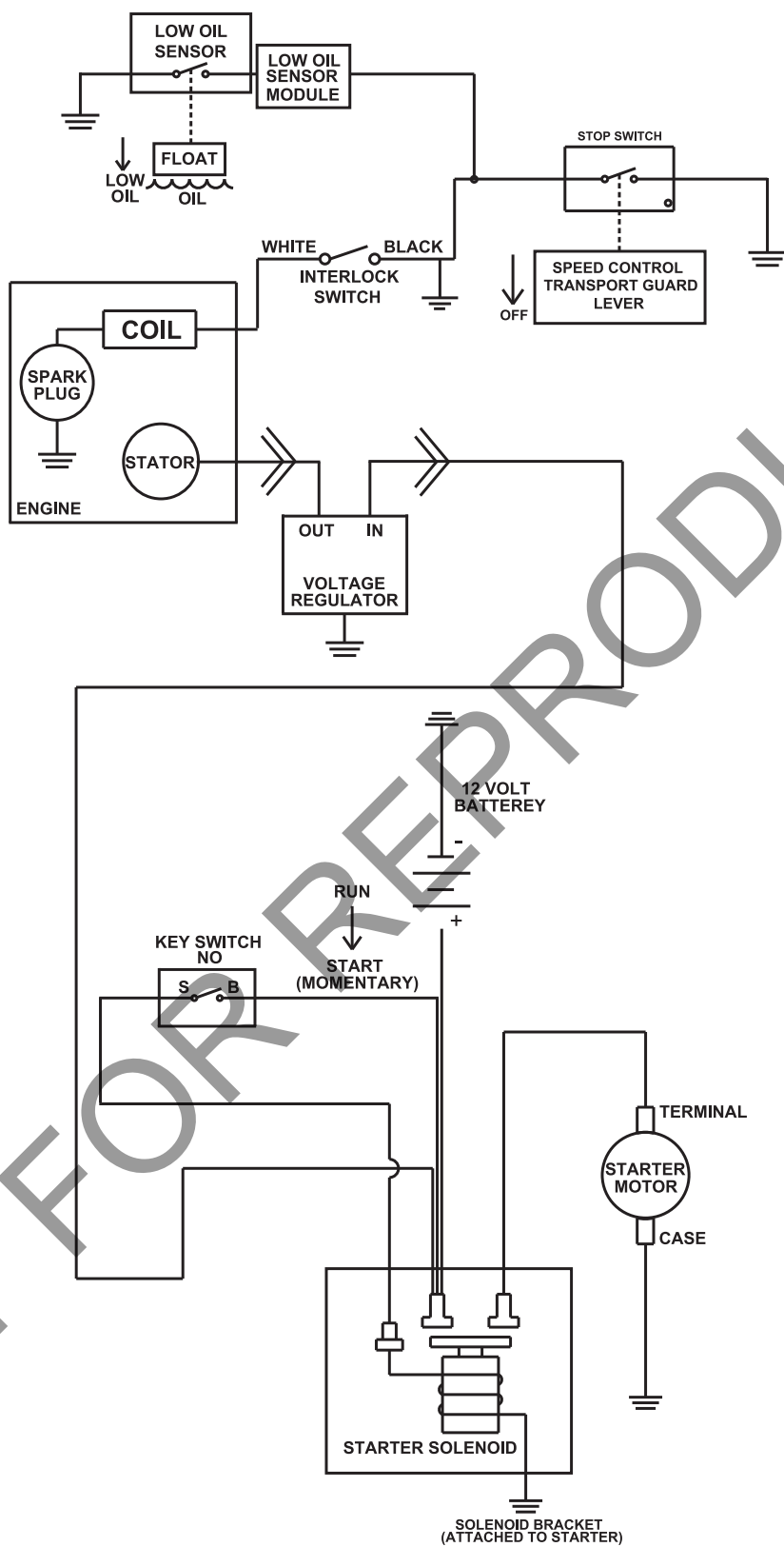

DL1802VEU Wiring Diagram

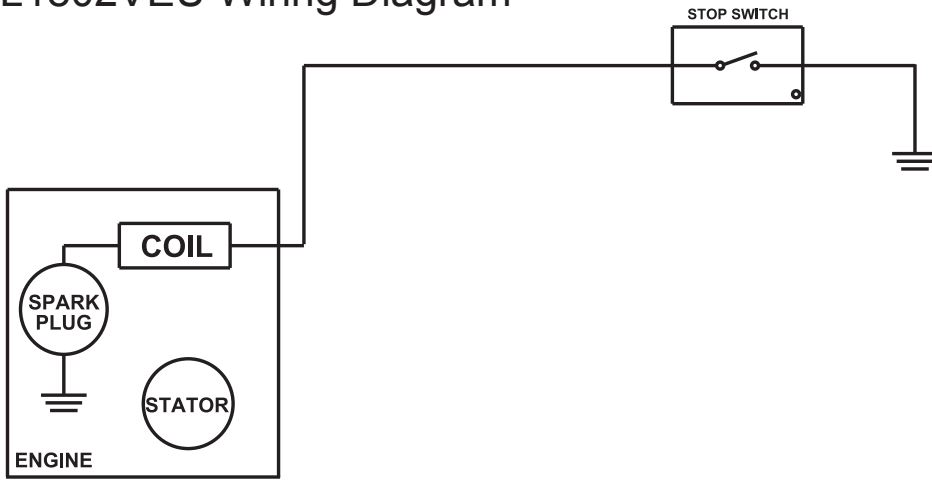

DL1802VEEU Wiring Diagram

