

ON-BOARD HOSE KIT 5" MV

P/N 840116

FOR MV MODELS



1803 S.W. Jefferson Street
 Lee's Summit, Mo. 64082-2312 / USA
 (816) 524-9666 Fax (816) 524-6983
 www.billygoat.com

PURPOSE: The on-board hose kit is to provide constant availability for vaccuming under bushes and other places where the machine cannot reach.

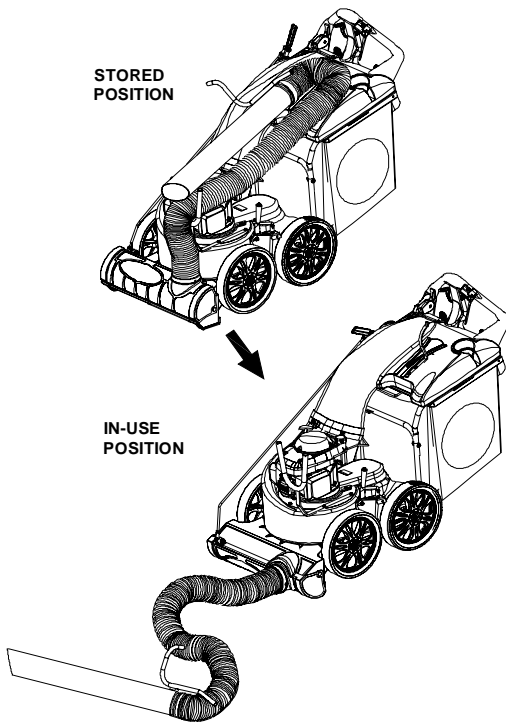

ITEM NO.	PART NUMBER	DESCRIPTION	QTY.
1	840182	TUBE, PLASTIC 5 IN X 40 IN LONG	1
2	840192	BRACKET HOSE KIT 5" HANDLE MV	1
3	890132	PLUG TUBE INSERT 1"	4
4	500267	GRIP HANDLE 1" X 5.5"	2
5	840193	TUBE HOSE KIT 5" HANDLE MV	1
6	840075	HOSE 5" X 87"	1
7	800279	CLAMP HOSE 5"	2
8	840156	TUBE 5" STEEL HOSE SWIVEL ADAPTER	1
9	840019-1	CAP 5" HOSE TRIMMED OUT	1
10	840174	BRACKET HOSE REST WA MV VAC	1
11	840093	BRACKET HOSE REST HOOD MV VAC	1
12	8172007	WASHER 1/4" SAE ZP	4
13	840199	SCREW SOCKET BUTTON HEAD 1/4-20X3/4"	2
14	8171002	WASHER 1/4" FC ZP	2
15	8160001	NYLON INSERT LOCKNUT 1/4-20 UNC	4
16	8172005	WASHER #10 SAE ZP	4
17	8164005	NYLON INSERT LOCKNUT 10-24 UNF	2
18	8059136	SCREWCAP #10-24 X 3/4" WF ZP	2
19	8172019	WASHER FENDER 1/4 ZP	2
20	8041004	1/4 - 20 x 0.75 HWH	2
21	8041006	SCREWCAP 1/4"-20X1" HCS ZP	2
22	840143	PLATE HOSE KIT NOZZLE REINFORCEMENT	1

HOSE KIT breakdown drawing

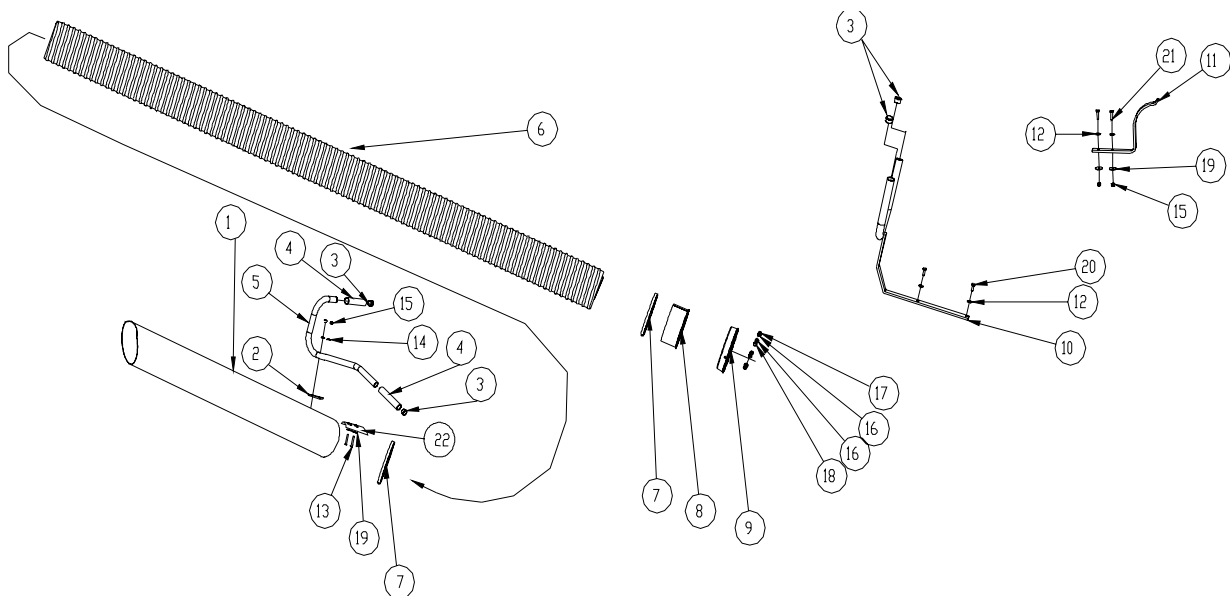

HOSE KIT P/N 840116

Reference pictures for mounting wire loop and the bracket

Tools required: socket drives and wrenches, 3/8", 7/16", 1/2", drill and drill bit 1/4", 5/32 Allen wrench

INSTALLATION:

1. Disconnect spark plug wire.
2. To install hood rest bracket (item 11). First remove bag assembly, then drill two 1/4" holes through dimples on hood coinciding with hose bracket. Attach using items #12, 19, 21, and 15.
3. To install U bracket hose rest. Remove self tapping screw (item 20), from left side of housing then mount bracket with items #12 and 20 in the holes that the screws were removed.

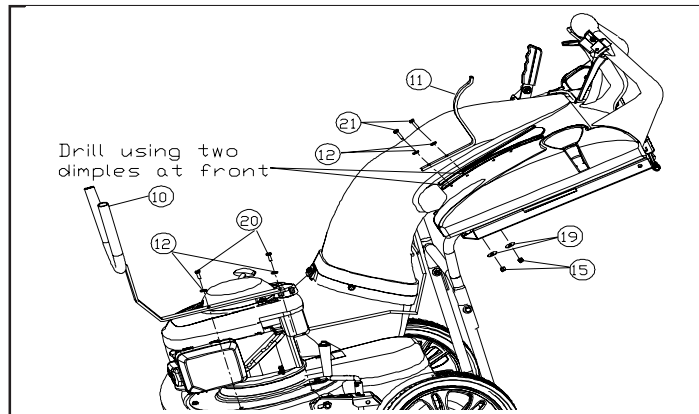

4. Attach hose to the vacuum nozzle by removing self tapping screws and cover. Align bolt holes on the adapter. Mount the bolts (item 18) from the inside out, with the nut and washers (items 16 and 17) on exterior of adapter.
5. Attach hose (item 1) to the hose adapter (item 8) and tighten the clamp (item 7).

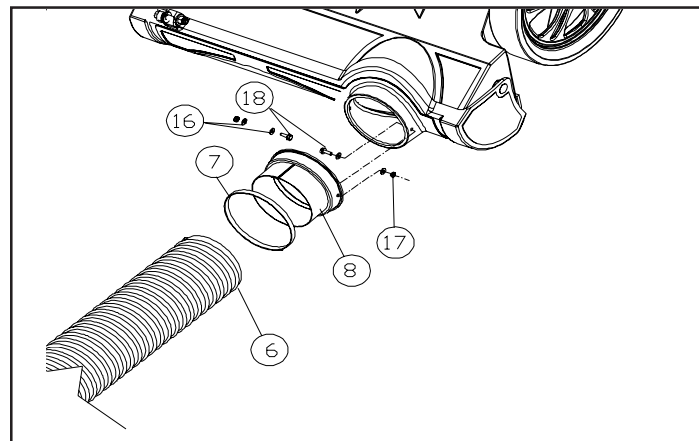

6. Install the handle by using bolts (item 13), washers (item 19 and 14) and nuts (item 15), reinforcement plate (item 22), and plate (item 2). Note: the reinforcement plate goes on the interior of the hose. Tighten the nuts and bolts securely
7. Slide the hose clamp (item 7) over the hose (item 6) but do not tighten.
8. Insert the nozzle (item 1) 2-3 inches into the hose, then tighten the clamp. Adjust nozzle to position where clamp will hold securely and not come apart during operation. When positioning is finished, tighten clamp down firmly.

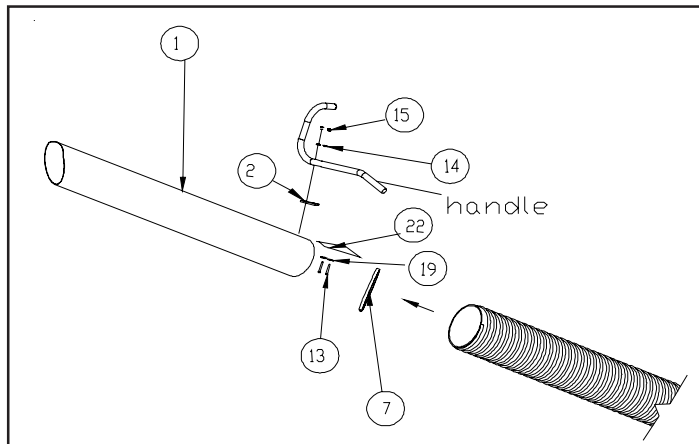

HINT: Lubricating nozzle will make hose slide on easier.

9. Reconnect spark plug wire.

OPERATION

- Remember to close nozzle door when using hose kit.
- Remove hose from store position before closing nozzle door.
- Do not bury nozzle in debris when using hose kit.

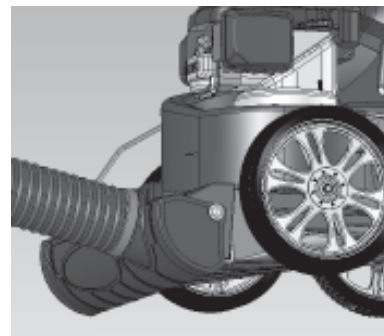

HOSE CARE & SHIPPING INFORMATION

SHIPPING TAG

IMPORTANT NOTICE

This merchandise was in perfect condition when packed and shipped.
Unpack immediately and check for damage.
Place any damage claim with delivering carrier and have inspection made at once.
Our warranty covers manufacturing defects only.

DO NOT RETURN TO SHIPPER.

SHIPPER-WARNING

TOPLOAD ONLY TO PREVENT SHIPPING DAMAGE.

HOSE CARE

ATTENTION!

- Hoses are wear items and are **only** warranted against manufactures defects. Hose must be inspected for shipping damage before using.
- Proper care is required to prevent damage. Operators should be cautious and keep the hose as straight as possible when vacuuming to not only help prevent clogging, but also to also help prevent abnormal wear to the sides of the hose. Rotate hose periodically to extend life. (Suggest ¼ turn every 20 hours.)
- Hose that has been exposed to extreme temperatures, chemicals, abrasive material or that have been run over will not be warranted.