



Image shown with optional accessories

KV VACUUM Owner's Manual

KV601, KV650H, KV601FB, KV650HFB

Beginning Serial #: 102515001

Accessories

ON BOARD VACUUM HOSE KIT	OPTIONAL FELT/MESH DEBRIS BAG	NOZZLE WEAR GUARD KIT	CASTER KIT	SHREDDER KIT	KV LINER KIT	PROTECTIVE COVER
4" x 7.5' (102mm x 2.13m) For vacuuming in hard to reach areas.	For use in leaves and grass in dusty conditions.	For use in increasing the life of your nozzle by protecting it from damage	To allow for easy rolling and maneuverability on smooth surfaces.	Shreds leaves, reducing total volume.	Increases the life of the housing by protecting it from damage.	Protects the machine from the environment when not in use.
P/N 891125	P/N 891126 FELT BAG P/N 891132 MESH BAG	P/N 891127	P/N 891128	P/N 891153	P/N 891134	P/N 891137

Original Instructions

IMPORTANT- READ CAREFULLY BEFORE USE AND KEEP FOR FUTURE REFERENCE.



CONTENTS

SPECIFICATIONS AND SOUND/ VIBRATION	3
INSTRUCTION LABELS	4
PACKING CHECKLIST	5
ASSEMBLY	6
OPERATION	7
MAINTENANCE AND TROUBLESHOOTING	8
ILLUSTRATED PARTS & PART LISTS	9-10
DECLARATION OF CONFORMITY	11-13

Go to <http://www.billygoat.com> for French-Canadian translations of the product manuals.

Visitez <http://www.billygoat.com> pour la version canadienne-française des manuels de produits.



KV PUSH Owner's Manual

SPECIFICATIONS

	KV601	KV650H	KV601FB	KV650HFB
Engine HP	4.95 (3.69 kW)	6.5 (4.85kW)	4.95 (3.69 kW)	6.5 (4.85kW)
Engine Type	B&S Professional Series	HONDA	B&S Professional Series	HONDA
Engine: Model	121R	GSV190LN1L	121R	GSV190N1L
Fuel capacity	1.2 qt. (1.14 L)	1.6 qt. (1.5 L)	1.2 qt. (1.14 L)	1.6 qt. (1.5 L)
Engine Oil capacity	0.56 qt. (0.53 L)	0.58 qt (0.54 L)	0.56 qt. (0.53 L)	0.58 qt (0.54 L)
Total Unit weight	#133 (60.3 kg)	113# (51.3kg)	#133 (60.3 kg)	113# (51.3kg)
Overall length	59" (1.5m)	59" (1.5m)	59" (1.5m)	59" (1.5m)
Overall width	26. 5" (0.7m)	26.5" (0.7m)	26. 5" (0.7m)	26.5" (0.7m)
Overall height	42.75" (1.1m)	42.75" (1.1m)	42.75" (1.1m)	42.75" (1.1m)
Max. operating slope	20 ⁰	20 ⁰	20 ⁰	20 ⁰
Sound in accordance with 2000/14/EEC standards	104 dBa	109 dBa	104 dBa	109 dBa
Sound at operator's ear	88.4 dBa	89 dBa	88.4 dBa	89 dBa
Vibration at operator position	0.29g (2.83m/s ²)	0.32 g (3.18m/s ²)	0.29g (2.83m/s ²)	0.32 g (3.18m/s ²)



KV PUSH Owner's Manual

INSTRUCTION LABELS

The labels shown below were installed on your BILLY GOAT® KV Vacuum. If any labels are damaged or missing, replace them before operating this equipment. For your convenience in ordering replacement labels, part numbers are included in the Illustrated Parts List. The correct position for each label may be determined by referring to the Figure and Item numbers shown.



LABEL DANGER KEEP HANDS AND FEET AWAY
ITEM #18 P/N 400424



LABEL SAFETY PROTECT ITEM #20
P/N 100346



DANGER FLYING DEBRIS
ITEM # 19 P/N 810736



LABEL EXPLOSIVE FUEL
ITEM # 16 P/N 400268



LABEL SPARK ARRESTOR
P/N 100252

BAG ENCLOSURE INSTRUCTION:
NOTE: IT IS IDEAL TO DO THIS PROCEDURE WITH THE BAG ON THE GROUND WITH BOTTOM PAD FACING UP.

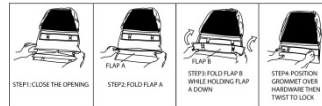

DEBRIS BAG FOLDING LABEL
LOCATED ON BAG

ENGINE LABELS

HONDA

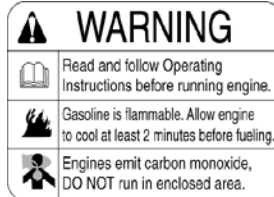
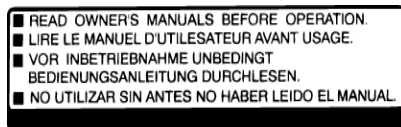

BRIGGS & STRATTON

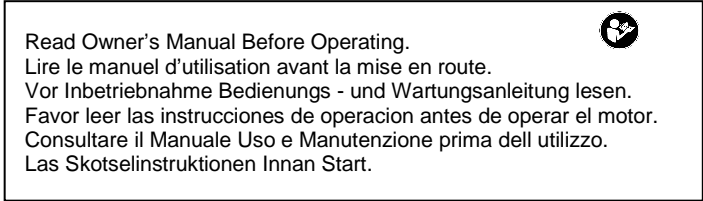

ENGINE CONTROLS



Honda Throttle Control



Briggs Throttle Control



KV PUSH Owner's Manual

PACKING CHECKLIST

Your Billy Goat KV Vacuum is shipped from the factory in one carton, completely assembled except for the upper handle, debris bag, and bag quick disconnect.



READ all safety instructions before assembling unit.
TAKE CAUTION when removing the unit from the box, the Handle Assembly is attached by cables and folded over.



PUT OIL IN ENGINE BEFORE STARTING

PARTS BAG & LITERATURE ASSY

Warranty card P/N- 400972, Owner's Manual P/N-891203, General Safety and Warnings Manual- 100294, Declaration of Conformity P/N-891057, Ty-Wraps 900407 (qty2).

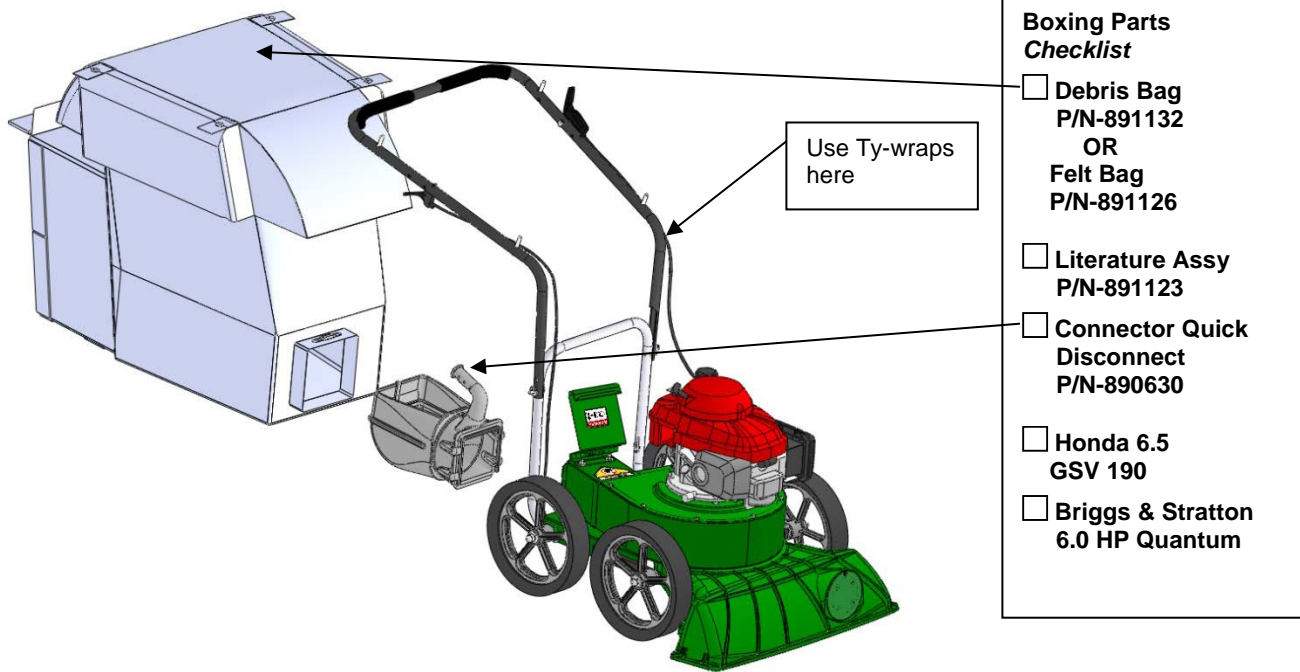

KV push hardware

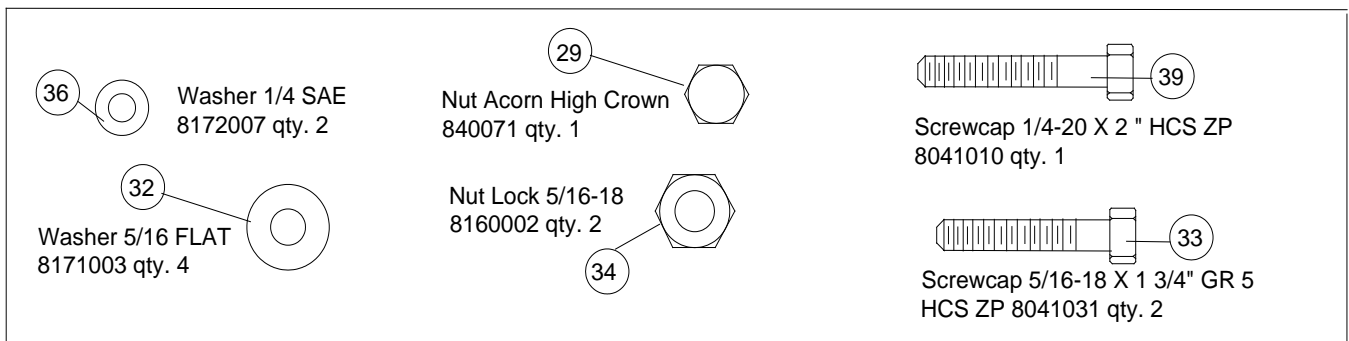



ASSEMBLY INSTRUCTIONS

NOTE: Items in () can be referenced in the Parts Illustration and Parts List on pages 10-11.

1. **ASSEMBLE** Lift upper handle (item 11), remove items 34, 32, and 33 from the parts bag. Attach and secure upper handle as shown using same hardware. (See Fig. 1)
2. **ATTACH** the throttle lever (item 23) to the handle, either to the right side or left depending on which model of engine you have (see image below). Attach the lever with the hardware (items 36, 37, and 39) found in the parts bag. Once attached use the Ty-wrap to secure the cable to the handle.
3. **UNFOLD** the debris bag (item 21) and fasten bag neck to bag quick disconnect (item 12). Attach firmly to housing exhaust (item 1) see Fig. 2 and 3.
4. **ATTACH** bag hanger strap to bag supports (item 13), preassembled to upper handle.
5. **CONNECT** spark plug wire.

Insert the quick disconnect from the inside of the bag, tilt the handle so it can be fed through first. Then slide the connecting end through and tighten the strap.

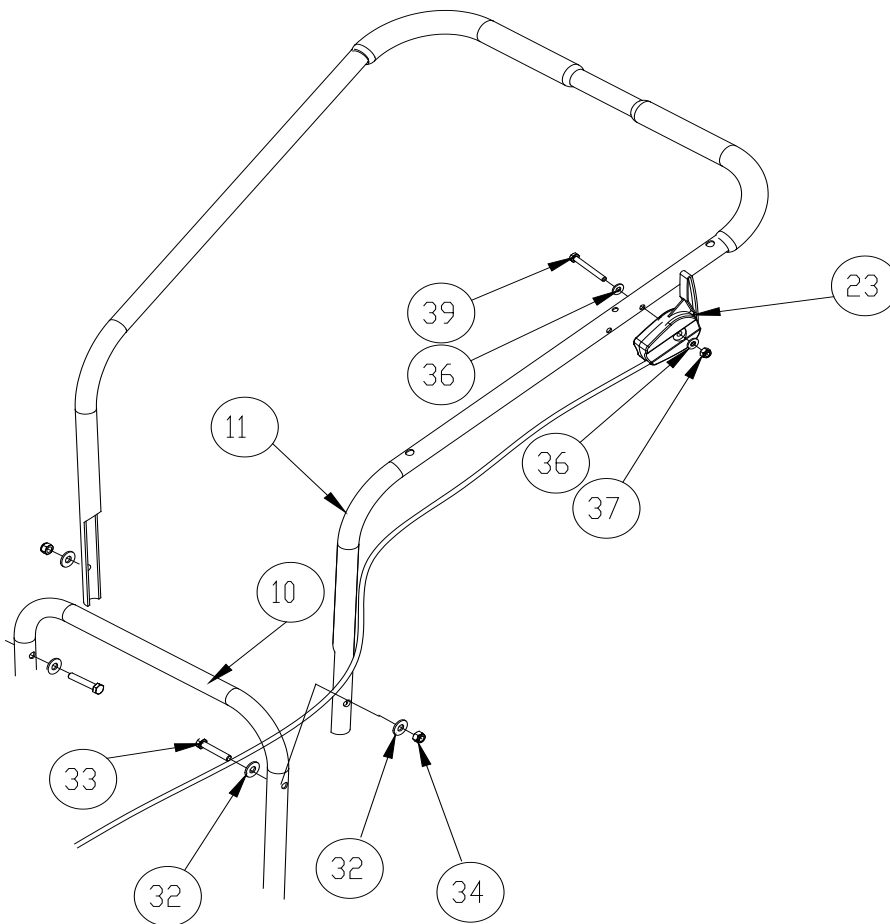

Fig. 1

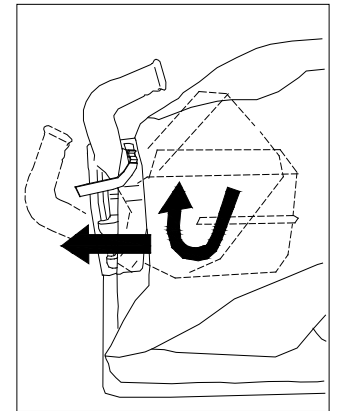

Fig. 2

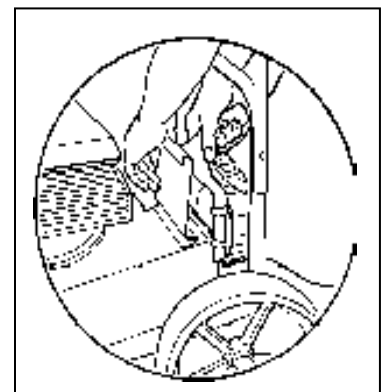

Fig. 3



OPERATION

VACUUMING OPERATION

VACUUM NOZZLE HEIGHT ADJUSTMENT: Nozzle height is raised and lowered by rotating the red knob near the left rear wheel. Nozzle height should be adjusted based on the task being performed. (See Fig. 4)

FOR MAXIMUM PICKUP: Adjust nozzle close to debris, but without blocking airflow into the nozzle. *NOTE:* Never bury nozzle into debris.

CLEARING A CLOGGED NOZZLE & EXHAUST: Turn the engine off and wait for impeller to stop completely and disconnect spark plug wire. Wearing durable gloves, remove clog.

DANGER, the clog may contain sharp materials. Reconnect spark plug wire.

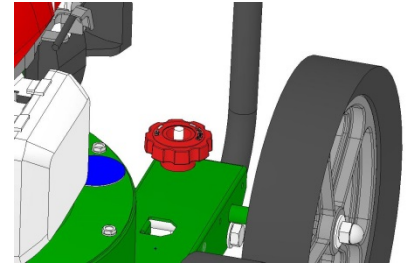
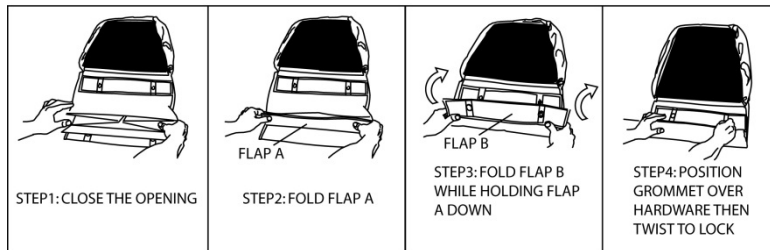

Fig. 4



BAG ENCLOSURE INSTRUCTION:

NOTE: IT IS IDEAL TO DO THIS PROCEDURE WITH THE BAG ON THE GROUND WITH BOTTOM PAD FACING UP.



DEBRIS BAG

Debris bags are normal replaceable wear items.

NOTE: Frequently empty debris to prevent bag overloading with more weight than you can lift.

An optional felt bag is available for use where debris will be vacuumed in dusty conditions (see "Accessories" shown on page 1).

DO NOT place bag on or near hot surface, such as engine. Be sure engine has come to a complete stop before removing or emptying bag.

This vacuum is designed for picking up trash, organic material and other similar debris (see "Safety and General Operation manual").

However, many vacuums are used where dust is mixed with trash. Your unit can intermittently vacuum in dusty areas. Dust is the greatest cause of lost vacuum performance. However, following these rules will help maintain your machine's ability to vacuum in dusty conditions:

- Run machine at idle to quarter throttle.
- The debris bag must be cleaned frequently. A vacuum with a clean, pillow soft bag will have good pickup performance. One with a dirty, tight bag will have poor pickup performance. If dirty, empty debris and vigorously shake bag free of dust.
- Pressure-wash debris bag if normal cleaning does not fully clean bag. Bag should be thoroughly dry before use.

NOTE: Having one or more spare debris bags is a good way to reduce down time while dirty bags are being cleaned.

DO NOT leave debris in bag while in storage.

COMPOST

Vacuumed leaves, grass and other organic material from your own yard can be emptied into a pile or composter to provide enriched soil for later use as fertilizer in gardens and flower beds. *NOTE:* Allow green chips to dry before spreading around living plants.



MAINTENANCE

PERIODIC MAINTENANCE

Periodic maintenance should be performed at the following intervals:

Maintenance Operation	Every Use (Daily)	Every 5 Hrs (Daily)
Inspect for loose, worn or damaged parts		●
Clean debris bag	●	
Check bag strap tightness	●	
Engine (See Engine Manual)		
Check for excessive vibration		●

IMPELLER REMOVAL

1. Wait for engine to cool and disconnect spark plug.
2. Drain fuel and oil from the engine.
3. Remove bag, quick release, and upper handle. Do not kink, stretch, or break control cables, control housings, or end fittings while removing handles.
4. Remove housing top plate by removing bolts around outside of housing.
5. Leaving engine fastened to top plate, turn it upside down so the impeller is on top.
6. Remove impeller bolt and lock washer and washer.
7. Lift impeller upward. If impeller slides freely, proceed to step 10.
8. To loosen Impeller, place two crowbars between impeller and housing on opposite sides. Pry impeller away from engine until it loosens. Using a penetrating oil can help loosen a stuck impeller.
9. If the impeller does not loosen, use two pry bars and pull the impeller near the hub away from the engine, this should loosen it and allow you to remove the impeller from shaft. Using a penetrating oil can help loosen a stuck impeller.
10. Using a new impeller bolt and lockwasher and washer, reinstall new impeller in reverse order.
11. Tighten impeller bolt. Torque impeller bolt to 33-38 Ft. Lbs. (44-51 N.m) (see item 30 on page 15).
12. Reinstall engine onto housing in reverse order of removal.
13. Gas and oil engine.
14. Reinstall spark plug wire.



KV PUSH Owner's Manual

TROUBLESHOOTING

Problem	Possible Cause	Solution
Abnormal vibration	Loose or out of balance impeller or loose engine.	Check impeller and replace if required. Check engine.
Will not vacuum or has poor vacuum performance	Dirty debris bag. Hose kit cap missing. Clogged nozzle or exhaust. Excessive quantity of debris. Improper nozzle height.	Clean debris bag. Shake bag clean or wash. Check for hose kit cap. Unclog nozzle or exhaust. Allow air to feed with debris. Adjust nozzle height so that it is closer to the debris.
Engine will not start	Throttle in off position. Engine not in full choke position. Out of gasoline. Bad or old gasoline. Sparkplug wire disconnected. Dirty air cleaner.	Check stop switches, throttle, choke position and gasoline. Connect spark plug wire. Clean or replace air filter, or contact a qualified service person.
Engine is locked, will not pull over	Debris locked in impeller. Engine problem.	See page 5. Contact a engine service dealer for engine problems.
Nozzle scrapes ground in lowest height setting	Nozzle height out of adjustment.	Adjust nozzle height (See Nozzle height fine adjustment for hard surfaces on page 7).
Too much dust coming from bag	Vacuuming very dry, brittle or small debris	Switch to felt bag (see page 1 "Accessories").



KV PUSH PARTS DRAWING

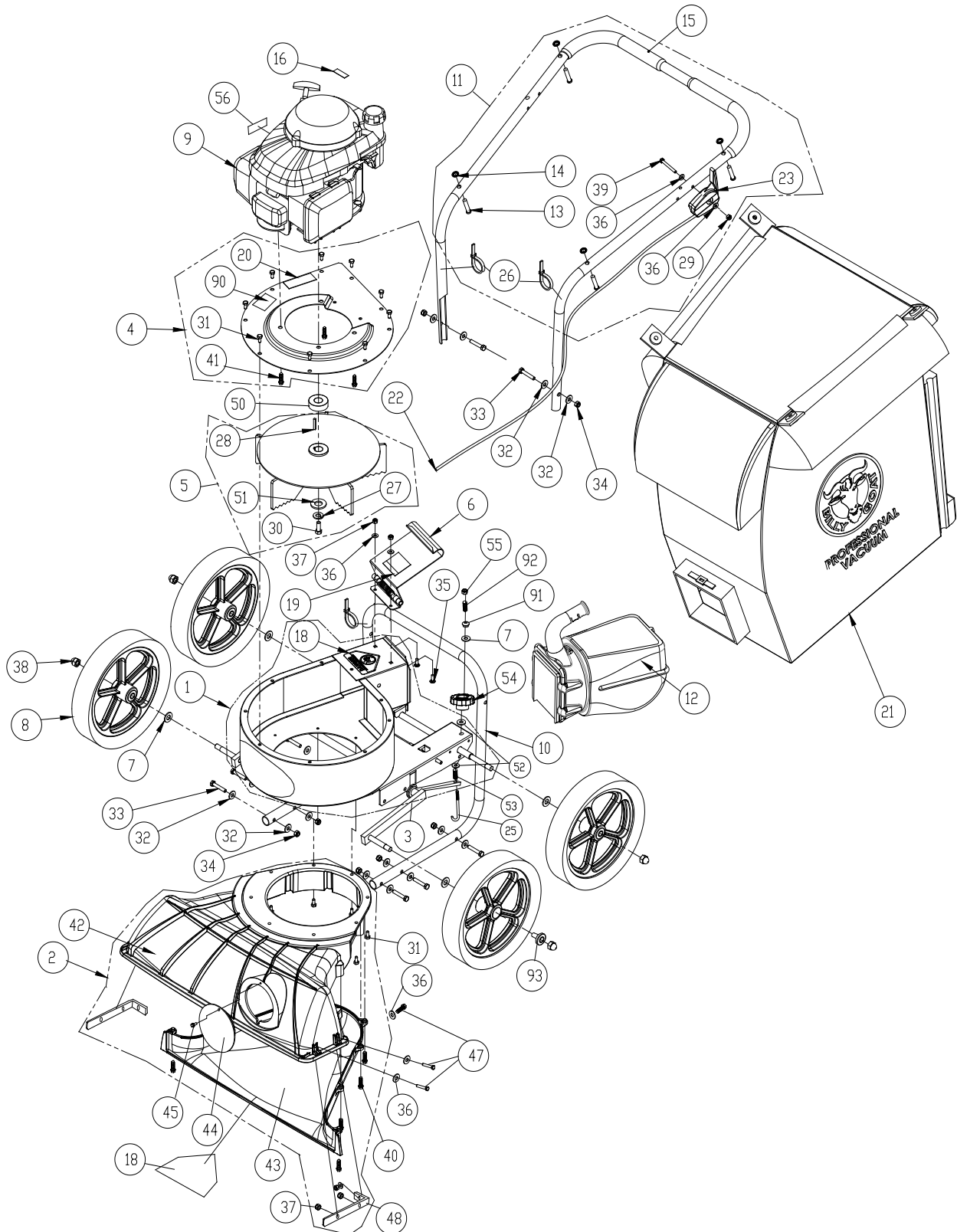



KV PUSH Owner's Manual

KV PUSH PARTS LIST

ITEM NO.	DESCRIPTION	KV601/KV601FB PART NUMBER	QTY	KV650H/KV650HFB PART NUMBER	QTY
1	MAIN FRAME HOUSING NEW KD	891100-S	1	891100-S	1
2	NOZZLE ASSEMBLY TKV	891110-S	1	891110-S	1
3	AXLE WA KV MICRO	891138	1	891138	1
4	PLATE TOP ENGINE KV	891007-1-S	1	891007-1-S	1
5	IMPELLER 12.75 WA PUSH VAC	891108-S	1	891108-S	1
6	DOOR EXHAUST ASSY RAW	890148	1	890148	1
7	WASHER 1/2" SAE Z/P	8172011	5	8172011	5
8	WHEEL ASSY 12" X 2.5" TREAD	900509-S	4	900509-S	4
9	ENGINE 6.5 HP HONDA GSV190AN1L	-	-	840069	1
	ENGINE B&S PRO SERIES 875	891218	1	-	-
10	LOWER HANDLE KV	891050	1	891050	1
11	HANDLE UPPER KV	891054-S	1	891054-S	1
12	QUICK DISCONNECT	890630	1	890630	1
13	PIN CLEVIS 3/8" x 2.125" LONG	520120	4	520120	4
14	RETAINER	360279	4	360279	4
15	GRIP HANDLE 1" X 9.5" LG	430342	2	430342	2
16	LABEL WARNING FUEL EN/SP	100261	1	-	-
18	LABEL WARNING DANGER	400424	2	400424	2
19	LABEL DANGER FLYING DEBRIS	810736	1	810736	1
20	LABEL SAFETY PROTECT READ MANUAL	100346	1	100346	1
21	BAG DEBRIS NO ZIPPER KV	891132	1	891132	1
	BAG FELT W/SKIRT (FB MODELS)	891211	1	891211	1
23	CABLE THROTTLE ASSY 42" W/CHOKE	891036	1	891027	1
25	BOLT J 3/8-16 X 6"	891071	1	891071	1
26	TY WRAP	900407	3	900407	3
27	WASHER LOCK 3/8" ST MED	8177012	1	8177012	1
28	KEY 3/16 SQ. X 1.25	9201080	1	9201080	1
29	NUT 1/4-20 ACORN	840071	1	840071	1
30	SCREWCAP 3/8-24X1 LOCKTITE	900154	1	-	-
	SCREWCAP 3/8-24X1 1/2" GR. 8	-	-	900344	1
31	SCREWCAP 1/4 - 20 x 5/8 HWH	890359	16	890359	16
32	WASHER 5/16 FLATWASHER Z/P	8171003	16	8171003	16
33	SCREWCAP 5/16-18 X 1.75 ZP	8041031	8	8041031	8
34	NUT LOCK 5/16-18	8160002	8	8160002	8
35	SCREWCAP 1/4-20 X 3/4"	8041004	2	8041004	2
36	WASHER 1/4" SAE ZP	8172007	10	8172007	10
37	NYLON INSERT LOCKNUT, 1/4-20 UNC	8160001	8	8160001	8
38	1/2-13 CAP NUT NP W/PATCH	890530	4	890530	4
39	SCREWCAP 1/4-20x2" HCS ZP	8041010	1	8041010	1
40	SCREW PLASTIC 1/4-10 X 1	891039	8	891039	8
41	SCREW 3/8 x 1 1/2 TAPTITE	890408	3	890408	3
42	NOZZLE TOP HALF KV	891002	1	891002	1
43	NOZZLE BOTTOM HALF KV	891003	1	891003	1
44	PLUG HOUSING KD LB	900146-01	1	900146-01	1
45	SCREW SELF TAPPING 10-24 X 1/2	891043	1	891043	1
46	LABEL KV PUSH	891045	1	891045	1
47	SCREWCAP 1/4-20 X 1"	8041006	6	8041006	6
48	BRACKET NOZZLE KV	891208	2	891208	2
50	SPACER 1.5 OD X .875 ID X .975 THK	-	-	890616	1
51	WASHER 1.5 OD X .453 ID X .25 THK	440153	1	440153	1
52	WASHER 1/2" FC	8171006	2	8171006	2
53	SPRING COMPRESSION	891072	1	891072	1
54	KNOB 3/8-16 RED	891070	1	891070	1
55	NUT LOCK 3/8-16 THIN	8161042	1	8161042	1
56	LABEL SPARK ARRESTOR EN/SP	-	-	100252	1
90	LABEL MADE IN U.S.A.	520116	1	520116	1
91	GROMMET FLANGE 1/2" MOLDED	830176	1	830176	1
92	SPRING COMPRESSION	400332	1	400332	1
93	BEARING BALL FLANGED	900774	4	900774	4



KV PUSH Owner's Manual



en	English	fi	Suomi	lv	Latviešu	ru	Русский
bg	Български език	fr	Français	nl	Nederlands	sl	Slovenščina
cs	Čeština	el	Ελληνικά	no	Norsk	sk	Slovák
da	Dansk	hr	Hrvatski	pl	Polski	sv	Svenska
de	Deutsch	hu	Magyar	pt	Português	tr	Türkçe
es	Español	it	Italiano	ro	Română		
et	eesti keel	lt	Lietuvių				

en	EC Declaration of Conformity	el	Δήλωση συμμόρφωσης ΕΚ	pl	Deklaracja zgodności UE
bg	Декларация за съответствие с европейските стандарти	hu	EU Megfelelőségi nyilatkozat	pt	Declaração de Conformidade à CE
cs	ES Prohlášení o shodě	hr	EC Deklaracija o sukladnosti	ro	Declarație de conformitate C.E.
da	EC Overensstemmelseserklæring	it	Dichiarazione di conformità CE	ru	Заявление о соответствии стандартам и нормам ЕС
de	EG-Konformitätserklärung	lt	EB atitikties deklaracija	sl	ES izjava o skladnosti
es	Declaración de Conformidad de la CE	lv	EK Atbilstības deklarācija	sk	Vyhlasenie o zhode
et	Eü vastavustunnistus	nl	E.G. Conformiteitsverklaring	sv	EG-försäkran om överensstämmelse
fi	EC-vaatimustenmukaisuusvakuutus	no	CE konformitetserklæring	tr	EC Uygunluk Deklarasyonu
fr	Déclaration de conformité CE				

en	Category	Vacuum	el	Κατηγορία	κενό	pl	Kategoria	Próżnia
bg	Категория	вакуум	hu	Kategória	vákuum	pt	Categoria	vácuo
cs	Kategorie	Vakuové	hr	Kategorija	Vakuum	ro	Categorie	vid
da	Kategori	vakuum	it	Categoria	vuoto	ru	Категория	вакуум
de	Kategorie	Vakuum	lt	Kategorija	Dulkių	sl	Kategorija	vakuumska
es	Categoría	Aspiradora	lv	Kategorija	vakuums	sk	Kategória	vákuové
et	Katagooria	vaakum	nl	Categorie	vacuüm	sv	Kategori	vakuum
fi	Kategoria	tyhjiö	no	Kategori	vacuum	tr	Kategori	Vakum
fr	Catégorie	vide						

en	This is to certify that the products listed in this document meet the requirements of the European Community Law, and can carry the CE mark. These models comply with the following Directives and related Standards.
bg	Декларацията се издава в удостоверение на това, че изброените продукти съответстват на стандартите на правните норми на Европейския съюз и могат да носят знака CE. Моделите изпълняват директивите и техните стандарти, както следва.
cs	Tímto stvrzujeme, že výrobky uvedené v tomto dokladu splňují požadavky zákonů Evropského společenství a mohou být označeny značkou CE. Tyto modely splňují následující směrnice a související normy.
da	Det bekræftes hermed, at de produkter, der er nævnt i dette dokument, opfylder bestemmelserne i EU-lovgivningen og kan bære CE-mærkatet. Disse modeller er i overensstemmelse med følgende direktiver og relaterede standarder:
de	Hiermit wird bescheinigt, dass die in diesem Dokument aufgeführten Produkte mit den gesetzlichen Bestimmungen der Europäischen Gemeinschaft übereinstimmen und das CE-Zeichen tragen können. Diese Modelle erfüllen die folgenden Richtlinien sowie weitere anzuwendende Normen.
es	La presente certifica que los productos enumerados en este documento cumplen con los requerimientos de la Legislación de la Comunidad Europea, y que pueden portar la marca CE. Estos modelos cumplen con las siguientes Directrices y Estándares relacionados:
et	Kinnitame, et eespool nimetatud tooted vastavad Euroopa Ühenduse seadusandluse nõuetele ja kannavad CE-märgistust. Eespool nimetatud mudelid vastavad järgmistele direktiividele ja seotud standardidele:
fi	Vakuutamme, että tässä asiakirjassa luetellut tuotteet täyttävät Euroopan Unionin lainsäädännön asettamat vaatimukset ja voi saada CE-merkinnän. Näitä mallit täyttävät seuraavien direktiivien ja niitä koskevien standardien vaatimukset:
fr	Nous déclarons par la présente que les produits mentionnés dans le document sont conformes à la législation de la Communauté européenne et peuvent porter le marquage CE. Ces modèles sont conformes aux directives suivantes et aux normes connexes :
el	Με την παρούσα δήλωση πιστοποιείται ότι τα προϊόντα που αναφέρονται στην παρούσα πληρούν τις απαιτήσεις της Ευρωπαϊκής Κοινωνικής Νομοθεσίας και μπορούν να φέρουν τη σήμανση CE. Τα μοντέλα αυτά συμμορφώνονται με τις ακόλουθες Οδηγίες και τα σχετικά Πρότυπα.
hu	Ez annak tanúsítására szolgál, hogy a dokumentumban felsorolt termékek megfelelnek az Európai közösségi jog követelményeinek és viselheti a CE jelzést. Ezek a modellek eleget tesznek a következő irányelveknek és vonatkozó szabványoknak.
hr	Ovo je potvrda da proizvodi koji su navedeni u ovom dokumentu odgovaraju zakonima europske zajednice i da nose CE oznaku. Ovi modeli zadovoljavaju sljedeće direktive i odgovarajuće standarde.
it	Si certifica che i prodotti elencati nel presente documento soddisfanno i requisiti della legislazione della Comunità Europea e possono recare il marchio CE. Questi modelli sono conformi alle seguenti norme e direttive:
lt	Šiuo patvirtiname kad šiame dokumente paminėti produktai atitinka Europos Bendrijos įstatymų reikalavimus ir jie gali būti pažymėti CE ženklu. Šie modeliai atitinka sekančias direktyvas ir standartus.
lv	Ar šo tiek apstiprināts, ka šajā dokumentā uzskaitītie izstrādājumi atbilst Eiropas Kopienas Likuma prasībām un var tikt marķēti ar emblēmu CE. Šie modeļi atbilst sekojošajām Direktīvām un attiecīgajām Normām.
nl	Hiermee wordt gecertificeerd dat de producten die in deze lijst staan opgesomd, voldoen aan de wettelijke voorschriften van de Europese Gemeenschap en mogen worden voorzien van de CE markering. Deze modellen voldoen aan de volgende richtlijnen en bijbehorende normen:
no	Dette sertifiserer at produktene som er nevnt i dette dokumentet oppfyller kravene som stilles av EU, og at de dermed kan CE-merkes. Disse modellene tilfredsstiller følgende direktiver og relaterte standarder:
pl	Niniejszym zaświadcza się, że produkty wymienione w niniejszym dokumencie spełniają wymogi Prawa Wspólnoty Europejskiej i mogą nosić oznakowanie CE. Modele te spełniają wymogi następujących dyrektyw i powiązanych norm.
pt	O presente documento certifica que os produtos listados neste documento atendem aos requisitos das Leis da Comunidade Europeia e podem levar a marca CE. Esses modelos estão de acordo com as seguintes diretivas e padrões relacionados.
ro	Prin prezenta se atestă faptul că produsele menționate în acest document îndeplinesc cerințele de Drept Comunitar European și pot purta sigla C.E. Aceste modele sunt în conformitate cu următoarele directive și standarde asociate.
ru	Настоящим удостоверяется, что перечисленные в этом документе изделия соответствуют требованиям законово Европейского Союза и могут быть обозначены знаком CE. Эти модели отвечают требованиям следующих директив и соответствующих стандартов.
sl	To služi kot potrditev, da izdelki, ki so navedeni v tem dokumentu, ustrezajo zahtevam zakonodaje Evropske skupnosti in so lahko opremljeni z oznako CE. Ti modeli so v skladu z naslednjimi direktivami in povezanimi standardi.
sk	Týmto vyhlasujeme, že výrobky uvedené v tomto dokumente, splňajú požiadavky zákonov ES a môžu byť označené značkou CE. Tieto modely vyhovujú nasledujúcim smerniciam príslušným normám.
sv	Härmed försäkras att produkterna som finns listade i detta dokument uppfyller kraven i Europeiska gemenskapens lagstiftning och kan förses med CE-märket. Modellerna uppfyller följande direktiv och tillhörande normer.
tr	Bu belgede belirtilen ürünlerin Avrupa Birliği Yasası gereksinimlerini karşılayarak CE işareti taşıyabilmelerini onaylamak içindir. Bu modeller aşağıdaki Direktif ve ilgili Standartlarla uyumludur



KV PUSH Owner's Manual

en	Directive:	2006/42/EC	hu	Irányelv:	2006/42/EC	pt	Directiva:	2006/42/EC
bg	Директива:	2006/42/EC	el	Οδηγία:	2006/42/EC	ru	Директива:	2006/42/EC
cs	Směrnice č.:	2006/42/EC	hr	Direktiva:	2006/42/EC	ro	Directiva:	2006/42/EC
da	Direktiv:	2006/42/EF	it	Direttiva:	2006/42/EF	sl	Direktiva:	2006/42/EF
de	Richtlinie:	2006/42/EG	lt	Direktyva:	2006/42/EG	sk	Smernica:	2006/42/EG
es	Directriz:	2006/42/EC	lv	Direktīva:	2006/42/EC	sv	Direktiv:	2006/42/EC
et	Direktiiviga:	2006/42/EÜ	nl	Richtlijn:	2006/42/EÜ	tr	Direktif:	2006/42/EÜ
fi	Direktiivi:	2006/42/EC	no	Direktiv:	2006/42/EC			
fr	Directives :	2006/42/CE	pl	Dyrektywy:	2006/42/CE			

en Model	Guaranteed Sound Power Level	Measured Sound Power Level	Sound Pressure Level at Operator's Ear (1)	Engine Net Power	Hand/Arm Vibration (2)	Mass
bg Model	Гарантирано ниво на звука	Измерено ниво на звука	Налягане на звука, измерено на нивото на ухото на оператора (1)	Мощност на двигателя	Вибрация на дланта и на ръката (2)	Маса
cs Model	Garantovaná hladina akustického výkonu	Změřená hladina akustického výkonu	Hladina akustického tlaku nameraná u ucha obsluhující osoby (1)	Užitečný výkon motoru	Vibration rukou/paří (2)	Váha
da Model	Garanteret støjniveau	Målt støjniveau	Lydtryksniveau ved brugerens øre (1)	Maskine Netto kraft	Vibration af hånd/arm (2)	Vægt
de Modell	Garantierter Schalleistungspegel	Gemessener Schalleistungspegel	Schalldruckpegel am Ohr der Bedienungsperson (1)	Motornettoleistung	Vibrationen an Hand/Arm (2)	Masse
es Modelo	Nivel garantizado de potencia acústica	Nivel medido de potencia acústica	Nivel de presión acústica en el oído del operador (1)	Potencia neta del motor	Vibración mano / brazo (2)	Masa
et Mudel	Garanteeritud helivõimsuse tase	Mõõdetud helivõimsuse tase	Helirõhu tase kasutaja kõva juures (1)	Masin puhas töötab	Võkumine käsi / käsivarre (2)	Massi
fi Malli	Taattu äänitehotaso	Mitattu äänitehotaso	Äänenpaine taso käyttäjän korvan tasolla (1)	Moottorin nettoteho	Käden/käsivarren värinä (2)	Paino
fr Modèle	Niveau de bruit garanti	Niveau de bruit mesuré	Niveau sonore au niveau de l'oreille de l'opérateur (1)	Puissance nette du moteur	Vibrations au niveau de la main/du bras (2)	Masse
el Μοντέλο	Εγγυημένη στάθμη ηχητικής ισχύος	Μετρηθείσα στάθμη ηχητικής ισχύος	Στάθμη ηχητικής πίεσης στο αυτί του χειριστή (1)	Καθαρή ισχύς κινητήρα	Χειροβραχιονική δόνηση (2)	Μάζα
hu Model	Garantált hangteljesítmény szint	Mért hangteljesítmény szint	Hangnyomás szint a gépközlekedő fülénél (1)	Motor hasznos teljesítménye	Kéz/kar vibráció (2)	Tömeg
hr Model	Zajambena razina snage zvuka	Izmerjena razina snage zvuka	Razina zvučnog tlaka na uhu rukovatelja (1)	Neto snaga motora	Vibracije šake/ruke (2)	Masa
it Modello	Livello acustico garantito	Livello acustico misurato	Livello di pressione acustica all'orecchio dell'operatore (1)	Potenza netta motore	Vibrazioni a mani/braaccia (2)	Massa
lt Modelis	Garantuotas triukšmo lygis	Pamatuotas triukšmo lygis	Garso spaudimo lygis įrangos naudotojui (1)	Variškio bendras galingumas	Rankenos vibracija (2)	Masė
lv Modelis	Garantētais skaņas jaudas līmenis	Izmērītais skaņas jaudas līmenis	Skaņas spiediena līmenis pie operatora ausis (1)	Dzinēja neto jauda	Rokas/pleca vibrācija (2)	Masa
nl Model	Gegarandeerd geluidsdrukniveau	Gemeten geluidsdrukniveau	Geluidsdrukniveau bij het oor van de gebruiker (1)	Netto motorvermogen	Trelling van hand/arm (2)	Mass
no Modell	Garantert lydsterkenivå	Målt lydsterkenivå	Lydtrykk-nivå ved operatørens øre (1)	Motorens netto krefter	Hånd/ arm-vibrasjon (2)	Masse
pl Model	Gwarantowany poziom mocy akustycznej	Zmierzony poziom mocy akustycznej	Poziom ciśnienia akustycznego w uchu operatora (1)	Moc netto silnika	Drżania ręk/ramienia (2)	Masa
pt Modelo	Nível de potência de som garantido	Nível de potência de som medido	Níveis de pressão do som no ouvido do operador (1)	Potência útil do motor	Vibração no mão/braço (2)	Massa
ro Model	Nivel de zgomot garantat	Nivel de zgomot măsurat	Nivel de presiune acustică la urechea operatorului (1)	Putere netă motor	Vibrație mână/braț (2)	Masă
ru Модель	Гарантированный уровень звуковой мощности	Измеренный уровень звуковой мощности	Уровень звукового давления на месте оператора (1)	Полезная мощность двигателя	Интенсивность вибрации на ладонях/руках (2)	Вес
sl Model	Zajambena raven zvočne moči	Izmerjena raven zvočne moči	Raven zvočnega tlaka pri ušesu uporabnika (1)	Izhodna moč motorja	Tresljaji na rokah (2)	Masa
sk Model	Zaručená hladina akustického výkonu	Nameraná hladina akustického výkonu	Hladina akustického tlaku pôsobiaceho na ucho obsluhy (1)	čistý výkon motora	Ruka/Rameno Vibrácia (2)	Masa
sv Modell	Garanterad ljudeffektivnivå	Uppmätt ljudeffektivnivå	Ljudtrycksnivå vid operatörens öra (1)	Motoreffekt netto	Hand-/ armvibrationer (2)	Massa
tr Model	Garantili Ses Gücü Seviyesi	Ölçülen Ses Gücü Seviyesi	Operatörün Kulakındaki Ses Basınç Seviyesi (1)	Makine Net Gücü	El/Kol Titre şimi (2)	Ağırlık
KV601	104.2 dB(A)	103.2 dB(A)	88.4 dB(A)	3.69 kW	2.83 m/s ²	60.3 kg
KV601FB	104.2 dB(A)	103.2 dB(A)	88.4 dB(A)	3.69 kW	2.83 m/s ²	60.3 kg
KV650H	110 dB(A)	109 dB(A)	89 dB(A)	4.85 kW	4.95 m/s ²	51.3 kg
KV650HFB	110 dB(A)	109 dB(A)	89 dB(A)	4.85 kW	4.95 m/s ²	51.3 kg
KV601SP	104.2 dB(A)	103.2 dB(A)	88.4 dB(A)	3.69 kW	2.83 m/s ²	60.3 kg
KV601SPFB	104.2 dB(A)	103.2 dB(A)	88.4 dB(A)	3.69 kW	2.83 m/s ²	60.3 kg
KV650SPH	110 dB(A)	109 dB(A)	89 dB(A)	4.85 kW	3.29 m/s ²	58.9 kg
KV650SPHFB	110 dB(A)	109 dB(A)	89 dB(A)	4.85 kW	3.29 m/s ²	58.9 kg
TKV650SPH	113 dB(A)	112 dB(A)	92 dB(A)	4.85 kW	3.29 m/s ²	64 kg
TK650SPHFB	113 dB(A)	112 dB(A)	92 dB(A)	4.85 kW	3.29 m/s ²	64 kg



KV PUSH Owner's Manual

(1) ISO 5395-1:2013 F.7 (EN 4871:1996)
(2) ISO 5395-1:2013 G.8 (EN 12096:1997, D.1)

en Manufacturing Place / Keeper of Documentation bg Място на производство / Архивар cs Místo výroby / Držitel dokumentace da Fremstillingssted / Indehaver af dokumentationen de Herstellungsort / Verantwortlicher für die Dokumentation es Lugar de manufactura / Guardián de documentación et Valmistamiskoht / Dokumentatsiooni hoidja fi Valmistuspaikka / Asiakirjojen haltija fr Lieu de fabrication / Personne chargée de conserver la documentation	el Τόπος κατασκευής / Υπεύθυνος τήρησης αρχείων τεκμηρίωσης hu Gyártás helye / A dokumentáció őrzője hr Mjesto proizvodnje / Čuvar dokumentacije it Sede di produzione / Archiviatore di documentazione lt Pagaminimo vieta / Dokumentacijos turėtojas lv Ražošanas vieta / Dokumentācijas glabātājs nl Productieplaats / Documentatiebeheerder no Produksjonssted / Dokumentasjonsholder	pl Miejsce produkcji / Osoba odpowiedzialna za przechowywanie dokumentów pt Local de Fabrico / Responsável pela Documentação ro Loc de fabricație / Păstrător documentație ru Место производства / Владелец документации sl Kraj izdelave / Hranitelj dokumentacije sk Miesto výroby / Dokumentácia majiteľa sv Tillverkningsplats / Dokumentförvaring tr Üretim Yeri / Doküman Sorumlusu
--	--	--

1803 S.W. Jefferson
Lees Summit, MO 64063-
0308 USA

Jeroen Engelen
Schepersweg 4a 6049CV
Herten, NL

Ted Melin
Engineering Manager

10/05/2015