

# 2 Main Body

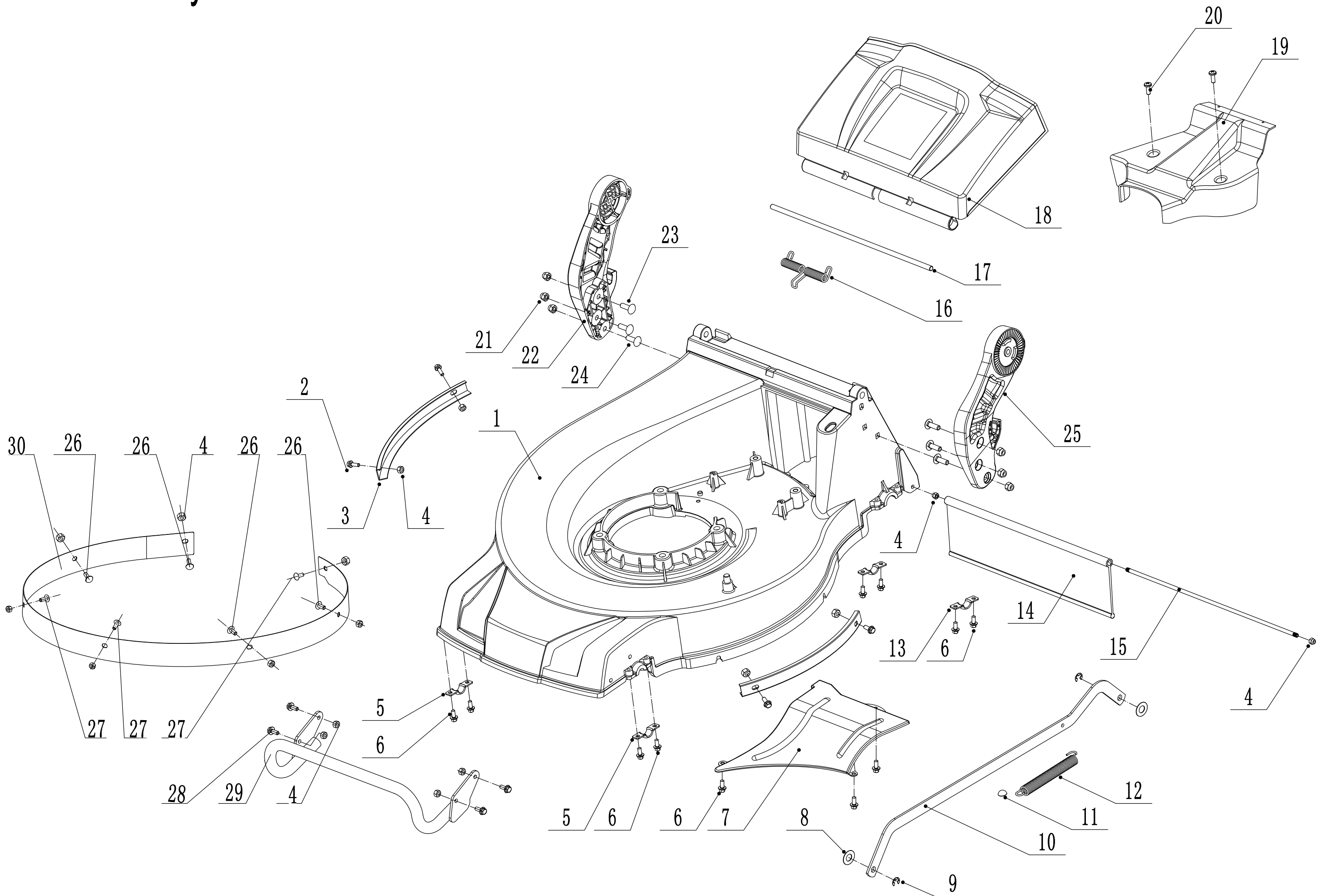

Ersatzteilliste Zeichnung Nummer 2		WB 486 SKL AL		2019
Nummer	Ersatzteilnummer	Deutsche Bezeichnung	Englische Bezeichnung	Menge
1	4860101010-49	Gehäuse	Chassis	1
2	0102006010	Bolzen	Bolt	4
3	4810103010-40	Schutz	Outside Protection Plate	2
4	0202006000	Mutter	Lock Nut	17
5	4820208010-01	Lagerhalter	Front Bearing Bracket	2
6	4820104010	Schraube	Screw	11
7	4820103010-49	Blech	Lower Baffle	1
8	4820306013	Ring	Nylon Mat	2
9	130008000	Ring	E-Clip	2
10	4860304010-40	Verbindungsstange	Connecting Rod	1
11	4820307011	Scheibe	Domed Grip Washer	1
12	4820307010-01	Feder	Spring- Connecting Rod	1
13	5320114020-01	Lagerhalter	Upper Bearing Bracket	2
14	4510111030	Schutz	Trailing Flap	1
15	5020117010-02	Stange	Pivot- Trailing Flap	1
16	4860106010	Feder	Spring- Rear Cover	1
17	4860105010-01	Stange	Pivot- Rear Cover	1
18	4860104010	Abdeckung	Rear Cover	1
19	4860103010	Abdeckung	Upper Belt Shield	1
20	4820122010	Schraube	Screw	2
21	0202008000	Mutter	Lock Nut	6
22	GM48S00000080-40	AVS Halter rechts	AVS Bracket R	1
23	4510513010-01	Bolzen	Bolt	2
24	4510513020-01	Bolzen	Bolt	4
25	GM48S000000070-40	AVS Halter links	AVS Bracket L	1
26	0109006014	Schraube	Screw	4
27	0109006016	Schraube	Screw	3
28	0102006016	Bolzen	Bolt	4
29	4860108010-40	Stoßstange	Bumper	1
30	4860109010-40	Bogenplatte	Inner Arc Plate	1

# 3 Blade System

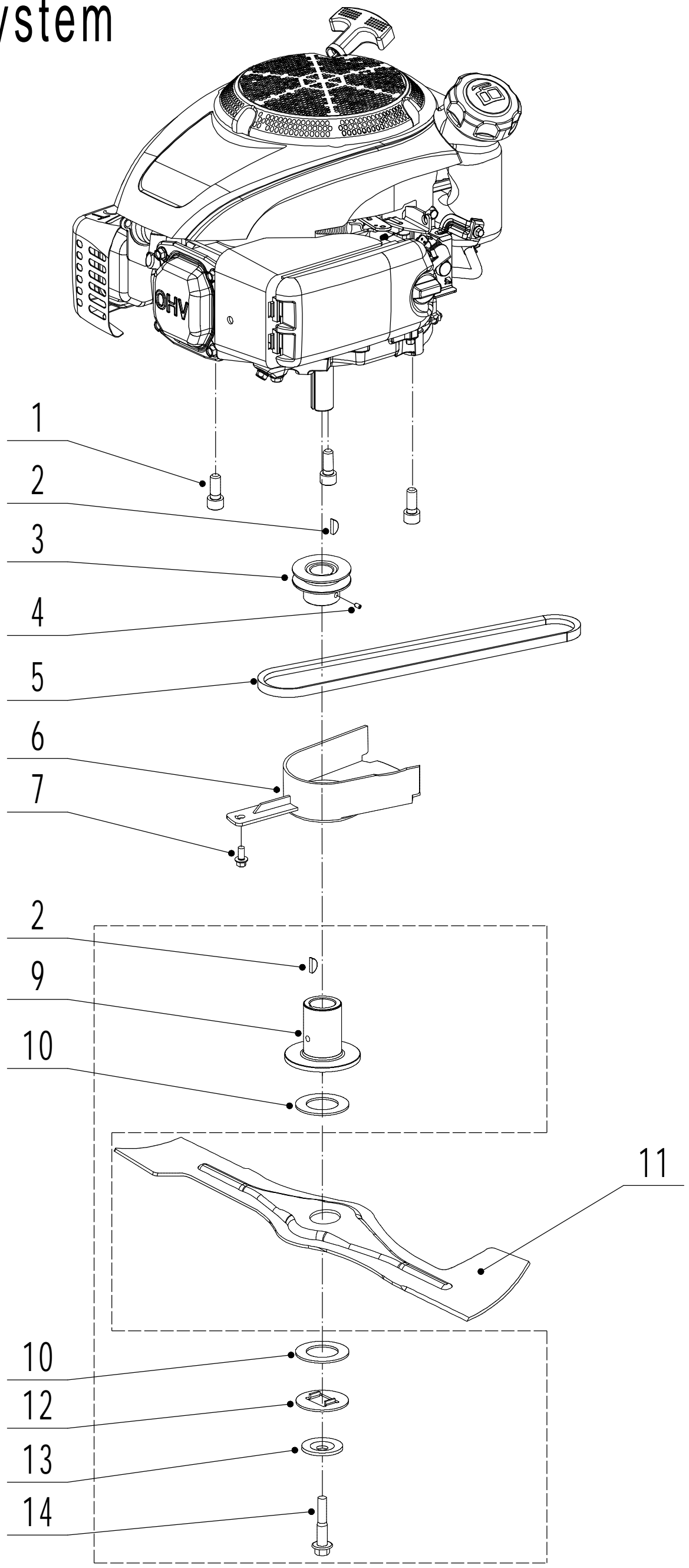

<b>Ersatzteilliste Zeichnung Nummer 3</b>		<b>WB 486 SKL AL</b>		<b>2019</b>
<b>Nummer</b>	<b>Ersatzteilnummer</b>	<b>Deutsche Bezeichnung</b>	<b>Englische Bezeichnung</b>	<b>Menge</b>
1	4820102010	Schraube	Screw	3
2	5310401010	Keil	Key	2
3	5380402020-02	Riemenscheibe	Engine Pulley	1
4	0105006006	Schraube	Screw	1
5	4840110011	Keilriemen	Belt	1
6	4820402011	Riemenschutz	Belt Shield	1
7	4820104010	Schraube	Screw	1
9	4510402010	Messerhalter	Blade Boss	1
10	5310402010	Friktionsscheibe	Friction Disc	2
11	4820403010A-22	Messer	Blade	1
12	5310404010-02	Ring	Locking Disc	1
13	5310406010-04	Scheibe	Dish Washer	1
14	5310415010	Messerschraube	Blade Bolt	1

# 4 Front axle

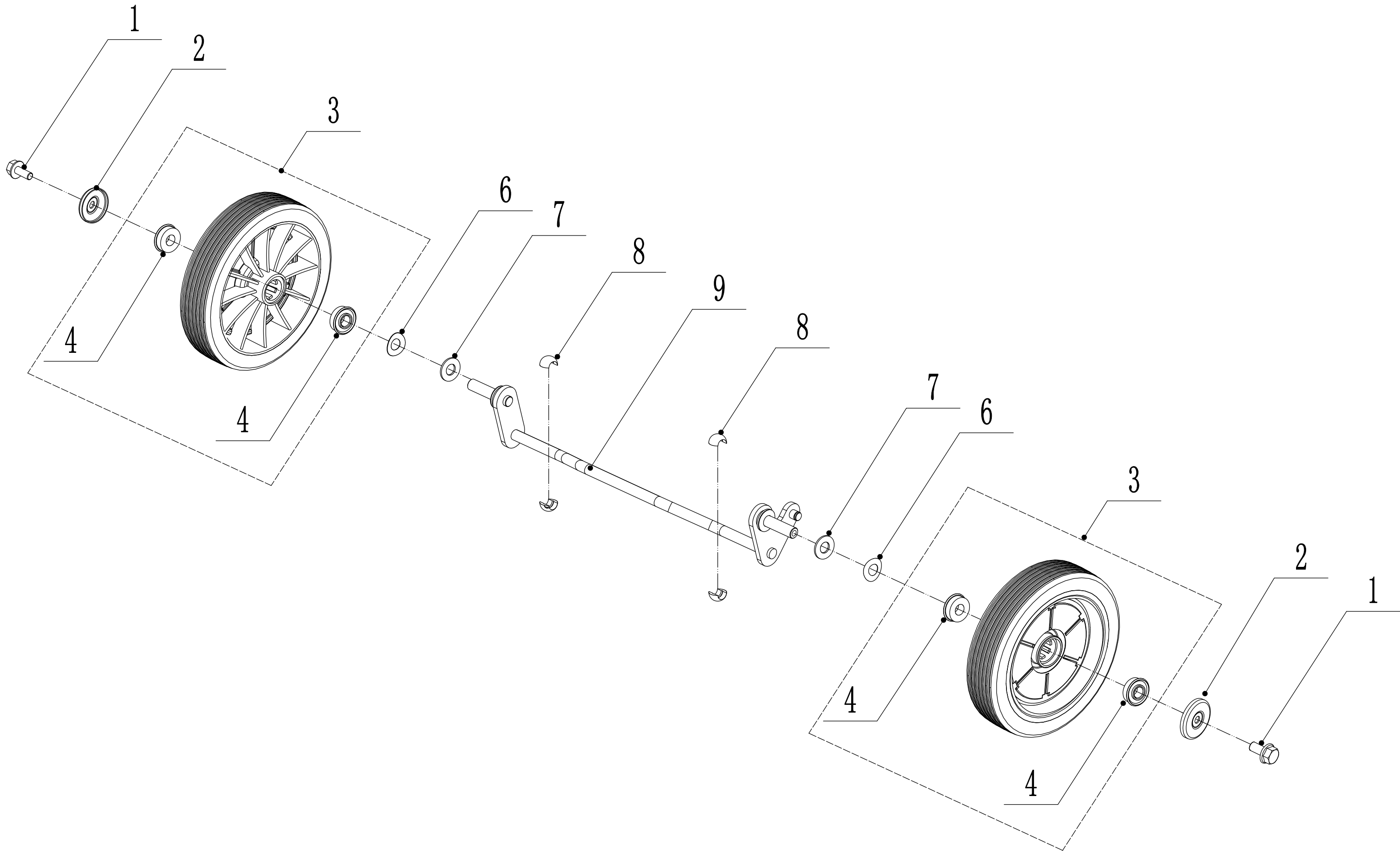

<b>Ersatzteilliste Zeichnung Nummer 4</b>		<b>WB 486 SKL AL</b>		<b>2019</b>
<b>Nummer</b>	<b>Ersatzteilnummer</b>	<b>Deutsche Bezeichnung</b>	<b>Englische Bezeichnung</b>	<b>Menge</b>
1	0102008016	Bolzen	Bolt	2
2	48R0210012-01	Radkappe	Wheel Cap	2
3	5340206011-40	Rad	Wheel Assembly	2
4	5310213010	Lager	Bearing	4
6	5310211010-02	Abstandshalter	Spacer	2
7	5310210010-02	Scheibe	Plain Washer	2
8	5310209010	Lager	Spherical Bearing	4
9	4820201010-01	Frontachse	Front Axle	1

# 5 Rear axle

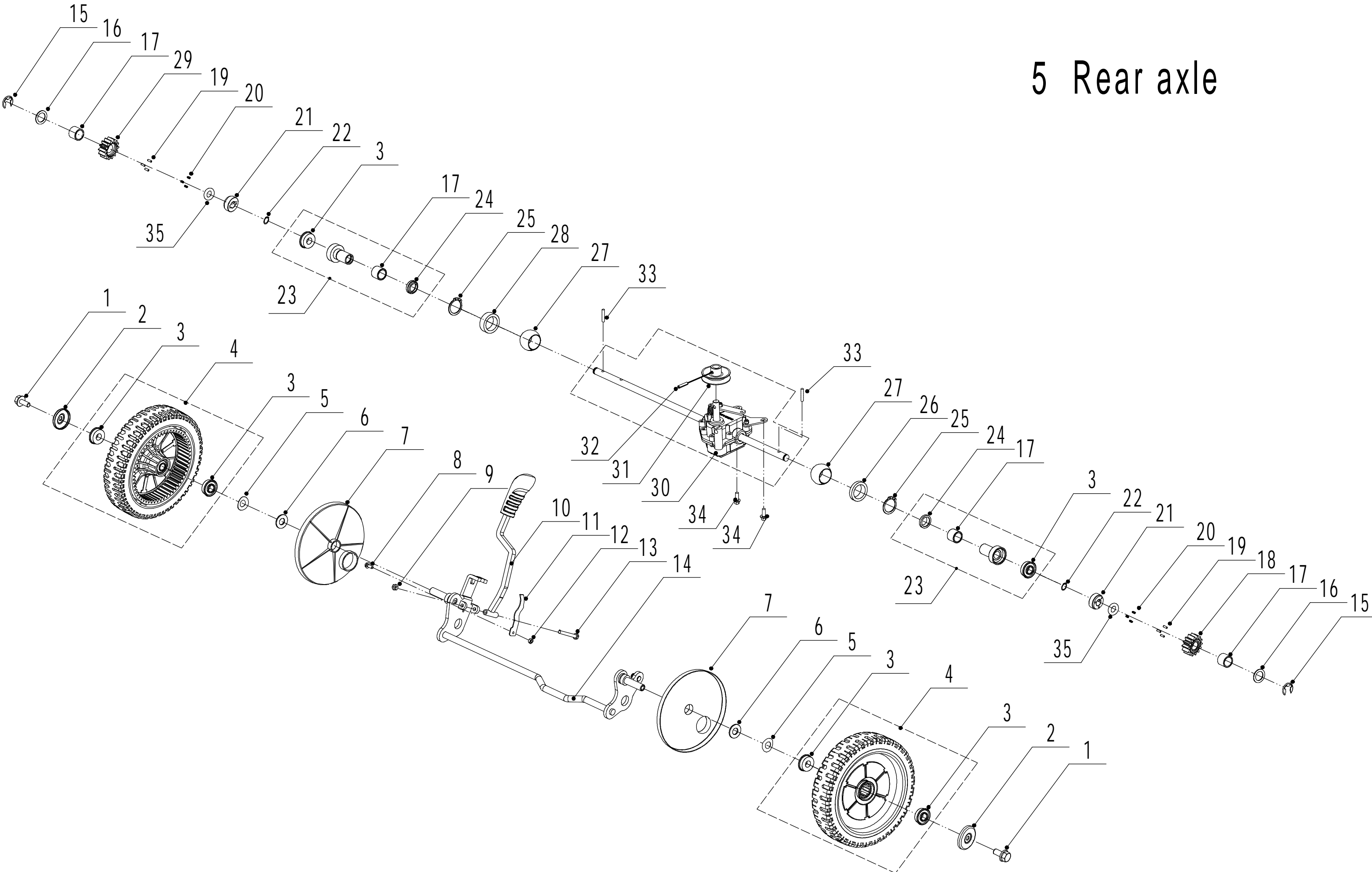

Ersatzteilliste Zeichnung Nummer 5		WB 486 SKL AL		2019
Nummer	Ersatzteilnummer	Deutsche Bezeichnung	Englische Bezeichnung	Menge
1	0102008016	Bolzen	Bolt	2
2	48R0210012-01	Radkappe	Wheel Cap	2
3	5310213010	Lager	Bearing	6
4	4820305011-40	Rad	Wheel Assembly	2
5	5310211010-02	Federscheibe	Spring Washer	2
6	5310210010-02	Scheibe	Plain Washer	2
7	4520308010	Hinterradabdeckung	Rear Wheel Shield	2
8	0101005016	Bolzen	Bolt	1
9	0202006000	Mutter	Lock Nut	1
10	5380311010-40	Höheneinstellhebel	Height Adjustment Lever	1
11	5380314010-04	Feder	Armature Spring	1
12	0202005000	Mutter	Lock Nut	1
13	0101006055	Bolzen	Bolt	1
14	4860301010-01	Hinterachse	Rear Axle Welding	1
15	1301009000	Ring	E-Clip	2
16	5020311010-04	Scheibe	Washer	2
17	5320326010P	Lager	Bearing	4
18	HQ000100010	Zahnrad links	Drive Pinion L	1
19	HQ000100030	Stift	Pin	6
20	HQ000100040	Feder	Spring	6
21	HQ000100050	Halter	Ratchet	2
22	1001012000	Sicherungsring	Circlip	2
23	Y065320	Lagerhalter	Bearing Sheath	2
24	5320327010	Staubabdeckung	Dustproof Ring	2
25	1001020000	Sicherungsring	Circlip	2
26	4820326010-02	Scheibe	Bearing Bracket Washer	1
27	5320328010	Lager	Nylon Ball Bearing	2
28	5320329010-02	Hülse	Rear Axle Partition	1
29	HQ000100020	Zahnrad rechts	Drive Pinion R	1
30	Y204860P	Getriebe	Gearbox	1
31	5020308020	Riemenscheibe	Gearbox Pulley	1
32	0701005020	Federstift	Spring Pin	1
33	HQ000100060	Stift	Check Holder	2
34	4820104010	Schraube	Screw	2
35	1401025015	Ring	O-Ring	2



# 6 Handle And Controls

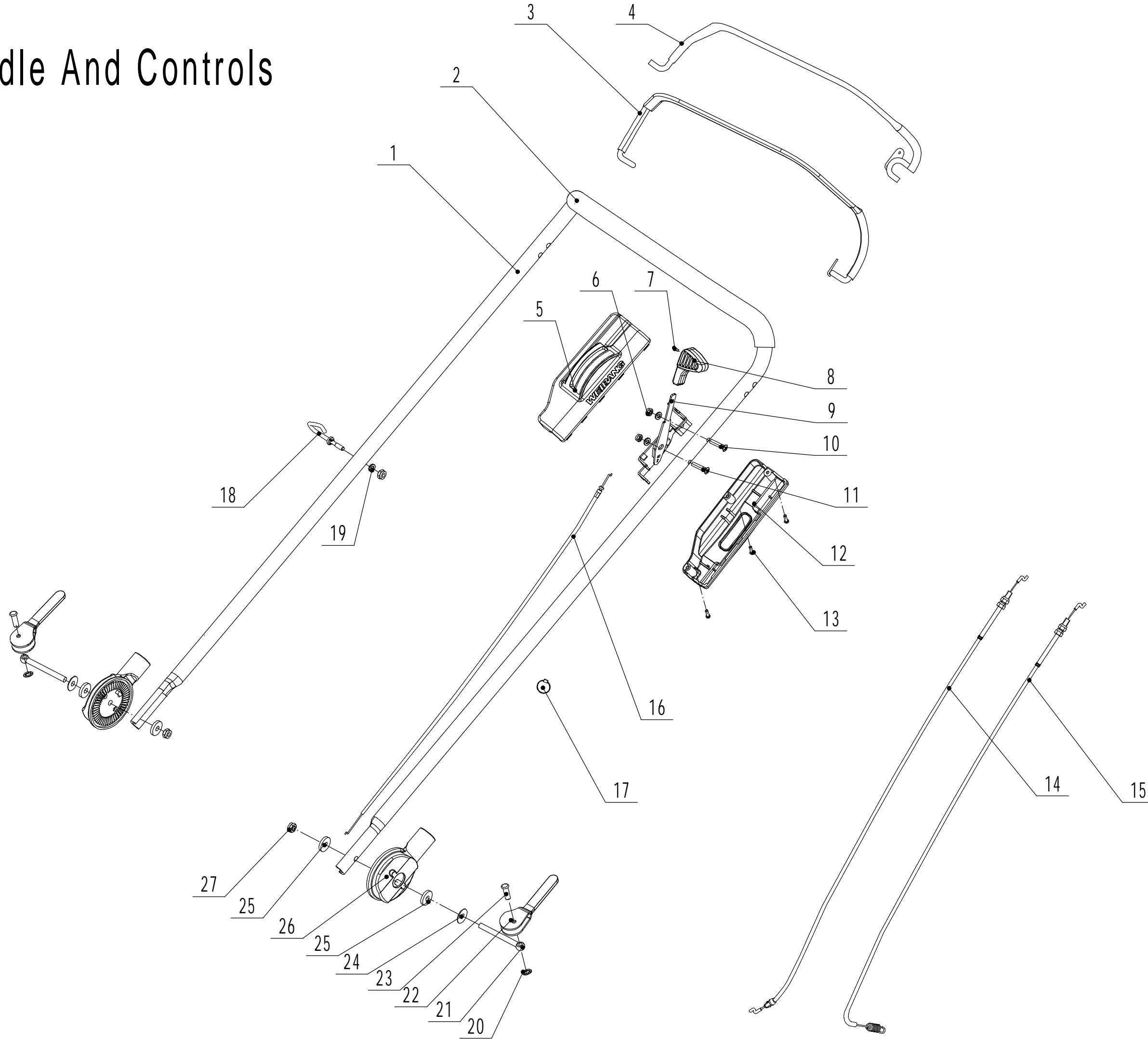

Ersatzteilliste Zeichnung Nummer 6		WB 486 SKL AL		2019
Nummer	Ersatzteilnummer	Deutsche Bezeichnung	Englische Bezeichnung	Menge
1	50205010020S-49	Holm	Handle	1
2	GM56E010000080	Griffschutz	Handle Sheath	1
3	5320511030S-40	Kupplungshebel	Clutch Lever	1
4	5320503020S-40	Hebel	OPC Lever	1
5	GM46E050000030	Kabelbox	Throttle Control Box	1
6	0202006000	Mutter	Lock Nut	3
7	0106003013	Schraube	Screw	1
8	5380510010	Knopf	Throttle Control Grip	1
9	GM46B050100000	Gashebel	Frame- Throtte Control	1
10	0108006040	Schraube	Screw	1
11	0108006050	Schraube	Screw	1
12	GM46E050000040	Kabelbox	Throttle Control Box	1
13	013040018	Schraube	Screw	3
14	BS120-1140	Bremskabel	OPC Cable	1
15	LH186-1195	Kupplungskabel	Clutch Cable	1
16	YM72-1040-A	Gaszug	Throttle Cable	1
17	ZD3-190	Ring	Cable Tie	1
18	4510511010-01	Haken	Hook- Starter Rope	1
19	0301006000	Scheibe	Washer	3
20	4510114030	Kappe	Fix Cap	2
21	GM48S000000100	Bolzen	Connecting Bolt	2
22	GM56A100400000	Hebel	Lock Lever	2
23	0801008022	Stift	Axis Pin	2
24	GM56A100000040-04	Abstandshalter	Spacer	2
25	GM56A100000050-01	Scheibe	Spacer	3
26	GM48S030200000	Verstellsegment	Tooth Disc Kit	2
27	0201008000DD	Mutter	Lock Nut	2

# 7 Grass Catcher

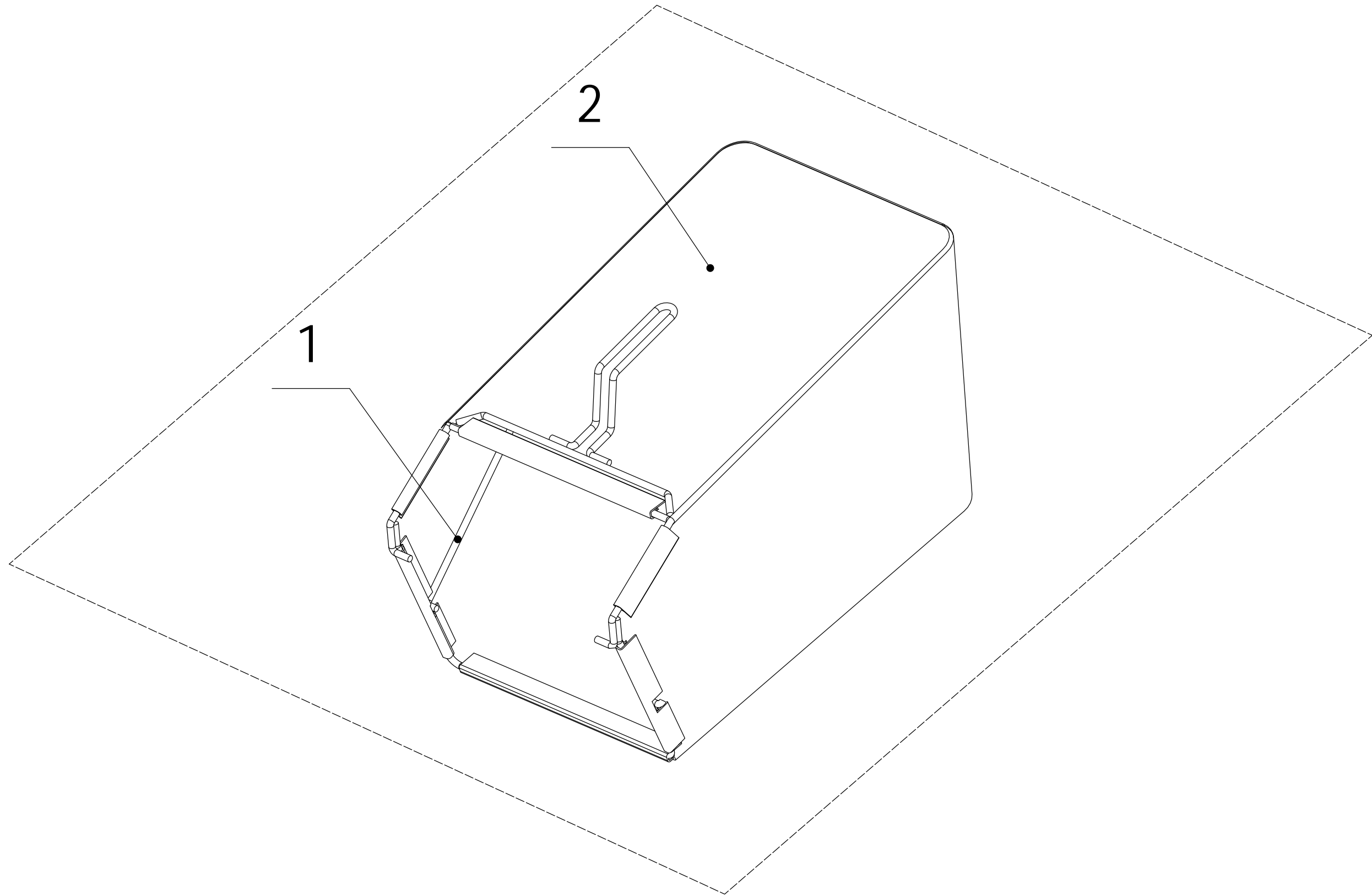

<b>Ersatzteilliste Zeichnung Nummer 7</b>		<b>WB 486 SKL AL</b>		<b>2019</b>
<b>Nummer</b>	<b>Ersatzteilnummer</b>	<b>Deutsche Bezeichnung</b>	<b>Englische Bezeichnung</b>	<b>Menge</b>
1	4860602010S-22	Gestell	Grass Bag Frame	1
2	4820611010S-84	Fangsack	Grass Bag	1

# 8 Variable Speed Pulley

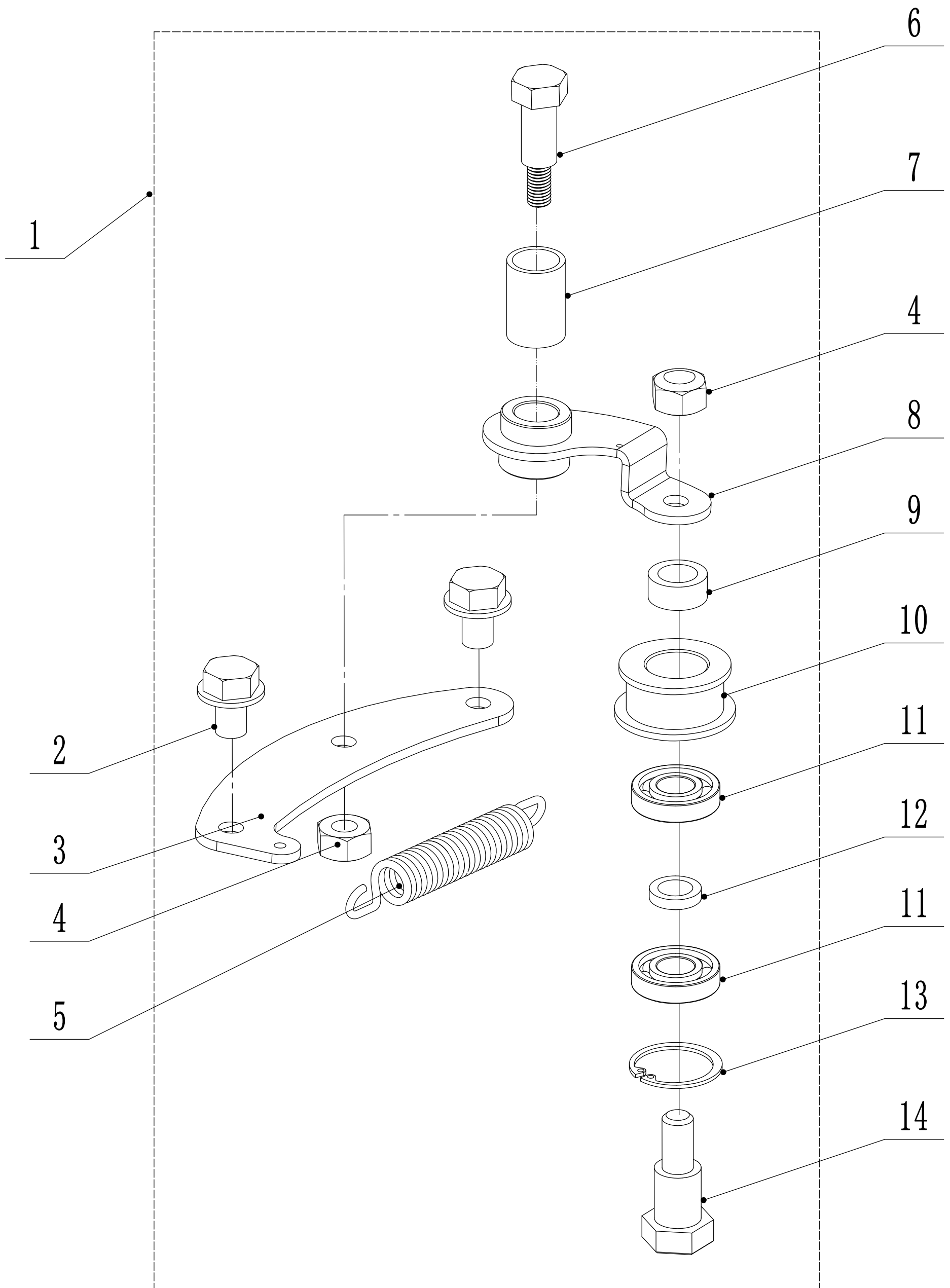

<b>Ersatzteilliste Zeichnung Nummer 8</b>		<b>WB 486 SKL AL</b>		<b>2019</b>
<b>Nummer</b>	<b>Ersatzteilnummer</b>	<b>Deutsche Bezeichnung</b>	<b>Englische Bezeichnung</b>	<b>Menge</b>
1	Y095341	Spannarm	Belt Tensioner Assembly	1
2	4820113010	Schraube	Screw	2
3	5340124010-02	Halter	Tensional Arm Bracket	1
4	0202008000	Mutter	Lock Nut	2
5	5340127010	Feder	Spring	1
6	5340126010-02	Bolzen	Central Bolt	1
7	4820112010	Hülse	Nylon Bush	1
8	5340125010-02	Halter	Swing Arm Welding	1
9	5340129010-02	Abstandshalter	Spacer	1
10	5340128010	Spannrolle	Tensional Pulley	1
11	609-2RS	Kugellager	Bearing	2
12	5340130010-02	Abstandshalter	Spacer	1
13	0901024000	Sicherungsring	Circlip	1
14	5340131010-02	Bolzen	Tensional Pulley Bolt	1