

# 2 Main Body

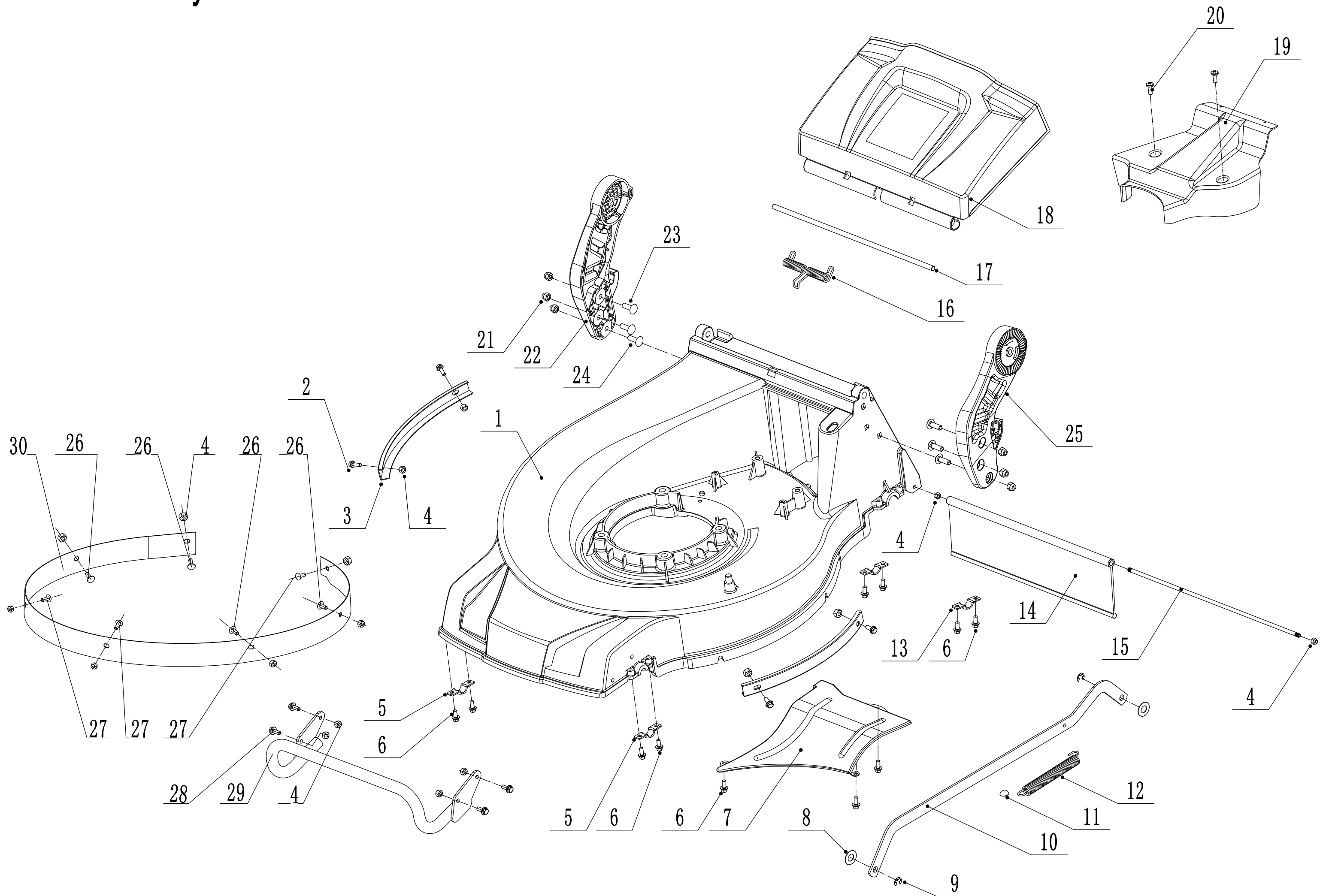

Ersatzteilliste Zeichnung Nummer 2		WB 486 SKL AL V		2019
Nummer	Ersatzteilnummer	Deutsche Bezeichnung	Englische Bezeichnung	Menge
1	4860101010-49	Gehäuse	Chassis	1
2	0102006010	Bolzen	Bolt	4
3	4810103010-40	Schutz	Protection Plate	2
4	0202006000	Mutter	Lock Nut	17
5	4820208010-01	Lagerhalter	Front Bearing Bracket	2
6	4820104010	Schraube	Screw	11
7	4820103010-49	Blech	Lower Baffle	1
8	4820306013	Scheibe	Nylon Mat	2
9	1301008000	Ring	E-Clip	2
10	4860304010-40	Verbindungsstange	Connecting Rod	1
11	4820307011	Scheibe	Domed Grip Washer	1
12	4820307010-01	Feder	Spring- Connecting Rod	1
13	5320114020-01	Lagerhalter	Upper Bearing Bracket	2
14	4510111030	Schutz	Trailing Flap	1
15	5020117010-02	Stange	Pivot-Trailing Flap	1
16	4860106010	Feder	Spring- Rear Cover	1
17	4860105010-01	Stange	Pivot- Rear Cover	1
18	4860104010	Schutz	Rear Cover	1
19	4860103010	Riemenschutz	Upper Belt Shield	1
20	4820122010	Schraube	Screw	2
21	0202008000	Mutter	Lock Nut	6
22	GM48S000000080-40	AVS Halter rechts	AVS Bracket R	1
23	4510513010-01	Bolzen	Bolt	2
24	4510513020-01	Bolzen	Bolt	4
25	GM48S000000070-40	AVS Halter links	AVS Bracket L	1
26	0109006014	Schraube	Screw	4
27	0109006016	Schraube	Screw	3
28	0102006016	Bolzen	Bolt	4
29	4860108010-40	Stoßstange	Bumper	1
30	4860109010-40	Verschleißblech	Inner Arc Plate	1

# 3 Blade System

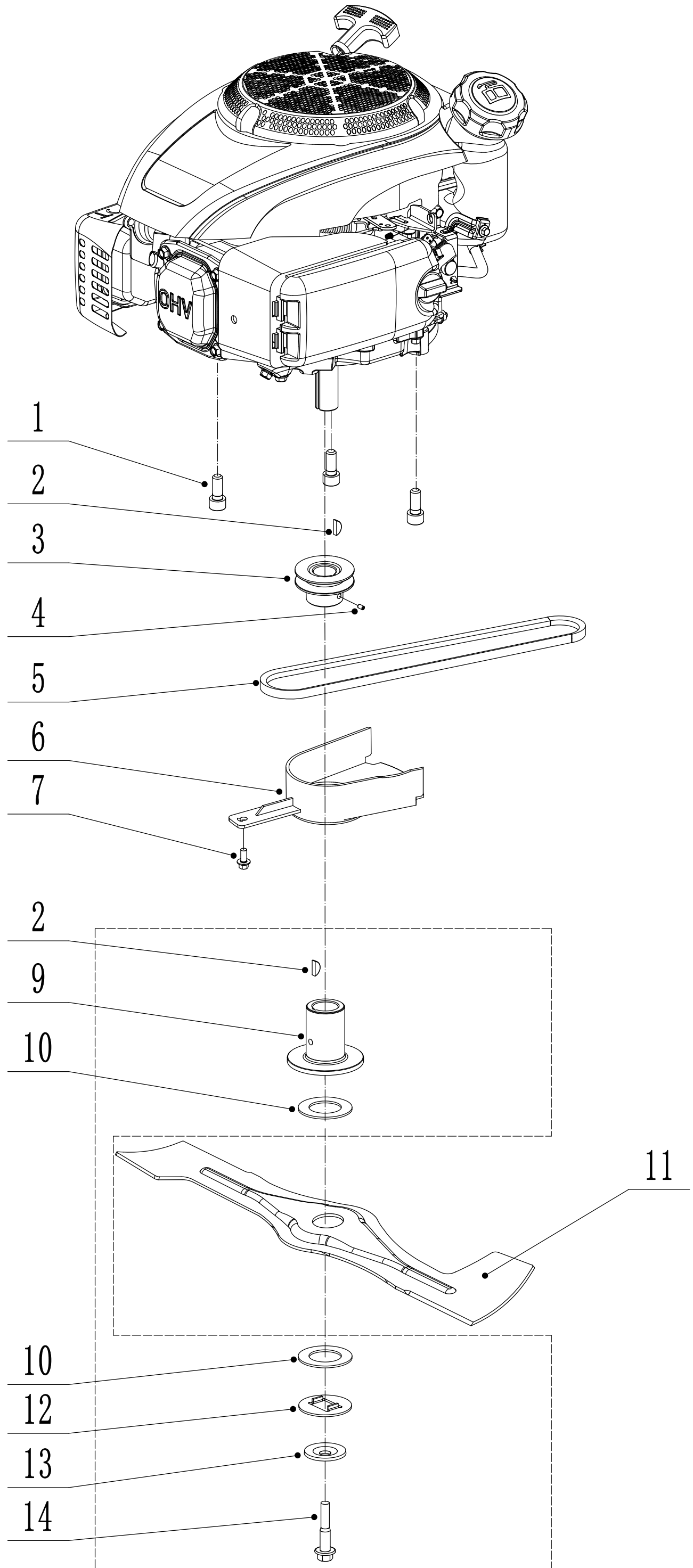

<b>Ersatzteilliste Zeichnung Nummer 3</b>		<b>WB 486 SKL AL V</b>		<b>2019</b>
<b>Nummer</b>	<b>Ersatzteilnummer</b>	<b>Deutsche Bezeichnung</b>	<b>Englische Bezeichnung</b>	<b>Menge</b>
1	4820102010	Schraube	Screw	4
2	5310401010	Keil	Key	2
3	5380402010	Riemenscheibe	Engine Pulley	1
4	010500606	Schraube	Screw	1
5	5320112010S	Keilriemen	Belt	1
6	4820402011	Riemenschutz	Belt Shield	1
7	4820104010	Schraube	Screw	1
9	5330402010-02	Messerhalter	Adaptor	1
10	5310402010	Friktionsscheibe	Friction Disc	2
11	4820403010A-22	Messer	Blade	1
12	5310404010-02	Ring	Locking Disc	1
13	5310406010-04	Scheibe	Dish Washer	1
14	5310415010	Messerschraube	Blade Bolt	1

# 4 Front axle

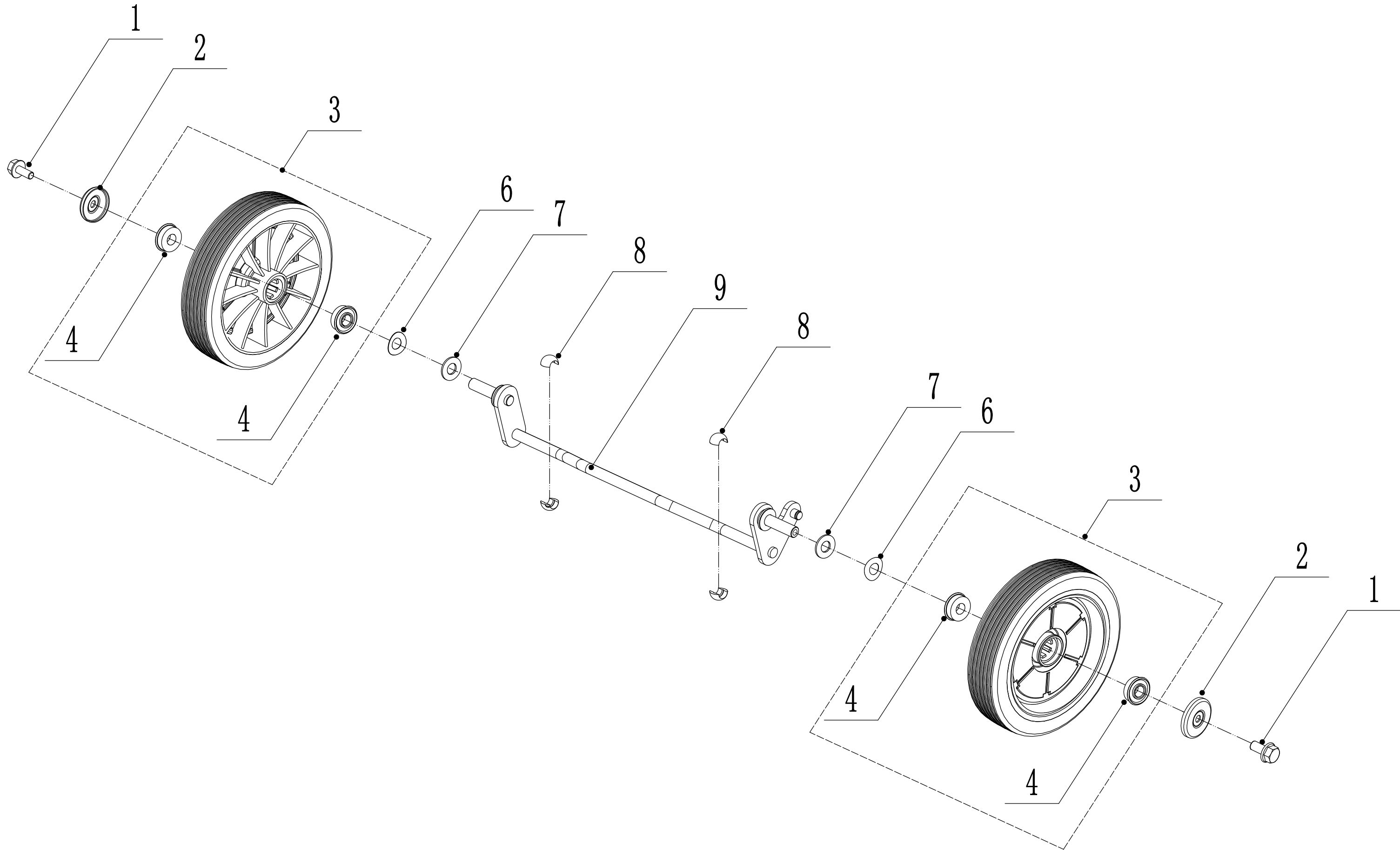

<b>Ersatzteilliste Zeichnung Nummer 4</b>		<b>WB 486 SKL AL V</b>		<b>2019</b>
<b>Nummer</b>	<b>Ersatzteilnummer</b>	<b>Deutsche Bezeichnung</b>	<b>Englische Bezeichnung</b>	<b>Menge</b>
1	0102008016	Bolzen	Bolt	2
2	48R0210012-01	Radkappe	Wheelcap	2
3	5340206011-40	Rad	Wheel Assembly	2
4	5310213010	Lager	Bearing	4
6	5310211010-02	Federscheibe	Spring Washer	2
7	5310210010-02	Scheibe	Plain Washer	2
8	5310209010	Lagerhalter	Bearing Holder	4
9	4820201010-01	Frontachse	Front Axle Welding	1

# 5 Rear axle

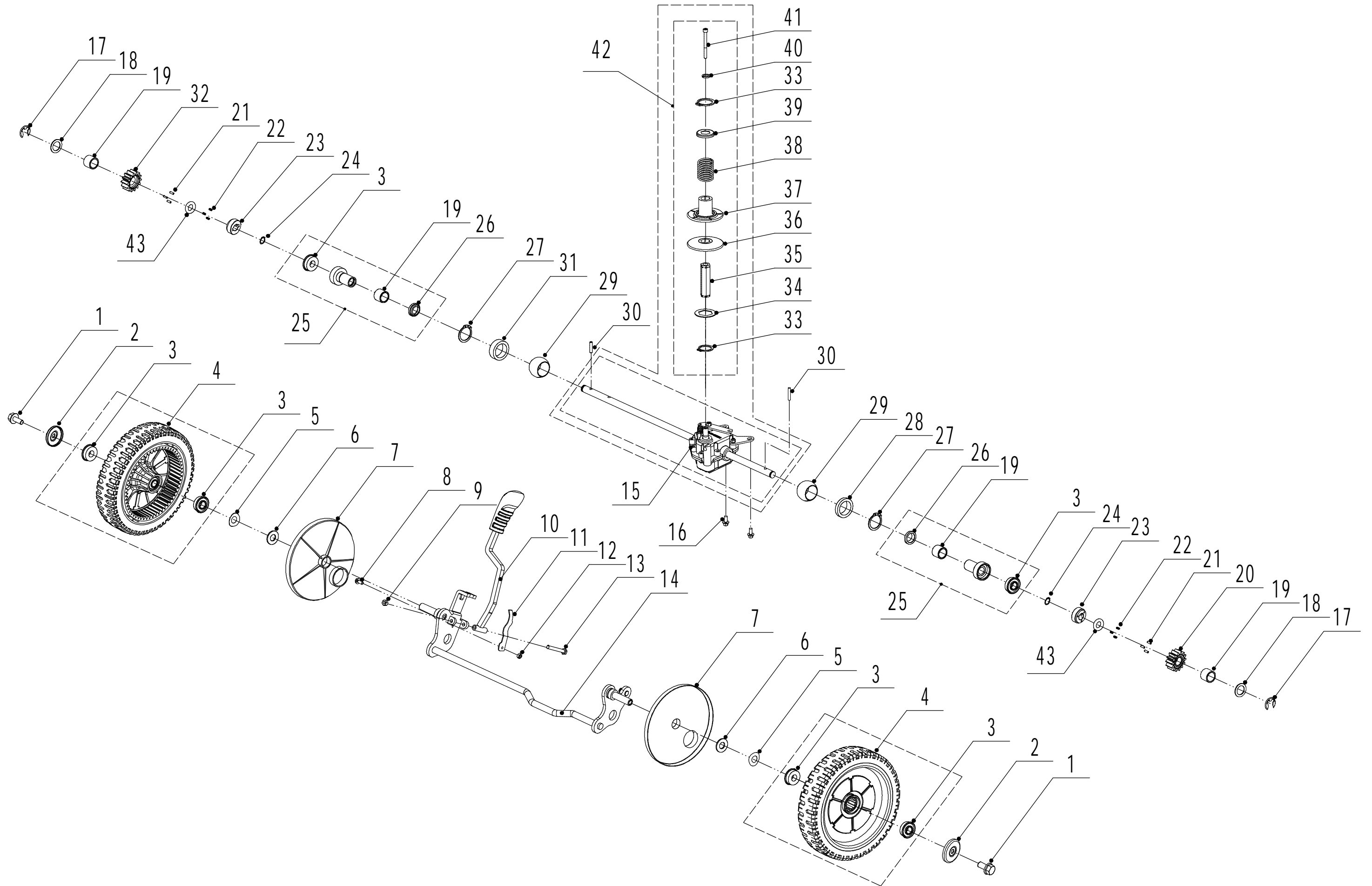

Ersatzteilliste Zeichnung Nummer 5		WB 486 SKL AL V		2019
Nummer	Ersatzteilnummer	Deutsche Bezeichnung	Englische Bezeichnung	Menge
1	0102008016	Bolzen	Bolt	2
2	48R0210012-01	Radkappe	Wheel Cap	2
3	5310213010	Lager	Bearing	6
4	4820305011-40	Rad	Wheel Assembly	2
5	5310211010-02	Federscheibe	Spring Washer	2
6	5310210010-02	Scheibe	Plain Washer	2
7	4520308010	Hinterradabdeckung	Rear Wheel Shield	2
8	0101005016	Bolzen	Bolt	1
9	0202006000	Mutter	Lock Nut	1
10	5380311010-40	Höheneinstellung	Height Adjustment	1
11	5380314010-04	Feder	Spring	1
12	0202005000	Mutter	Lock Nut	1
13	0101006055	Bolzen	Bolt	1
14	4860301010-01	Hinterachse	Rear Axle Welding	1
15	Y20486V0P	Getriebe	Rear Transmission	1
16	4820104010	Schraube	Screw	2
17	1301009000	Ring	E-Clip	2
18	5020311010-04	Scheibe	Washer	2
19	5320326010P	Lager	Bearing	4
20	HQ000100010	Zahnrad links	Drive Pinion L	1
21	HQ000100030	Stift	Pin- Drive Pinion	6
22	HQ000100040	Feder	Spring- Drive Pinion	6
23	HQ000100050	Halter	Block- Drive Pinion	2
24	1001012000	Sicherungsring	Circlip	2
25	Y065320	Lagerhalter	Bearing Sheath	2
26	5320327010	Staubabdeckung	Dustproof Ring	2
27	1001020000	Sicherungsring	Circlip	2
28	4820326010-02	Scheibe	Bearing Bracket Washer	1
29	5320328010	Lager	Nylon Ball Bearing	2
30	HQ000100060	Stift	Check Holder	2
31	5320329010-02	Hülse	Rear Axle Partition	1
32	HQ000100020	Zahnrad rechts	Drive Pinion R	1
33	1001017000	Sicherungsring	Circlip	2
34	4820320010-02	Scheibe	Inner Hex Washer	1
35	4820321010-02	Splint	Hex Adapter	1
36	5380309010	Scheibe	Lower Pulley Disc	1
37	5380308010	Variatorhälfte	Active Pulley Disc	1
38	4820324010	Feder	Spring	1
39	4820325010-02	Kappe	Spring Cap	1
40	0401005000	Federscheibe	Spring Washer	1
41	0103005055	Bolzen	Bolt	1
42	Y115380	Variator	Speed Variator Assembly	1
43	1401025015	Ring	O-Ring	2



# 6 Handle And Controls

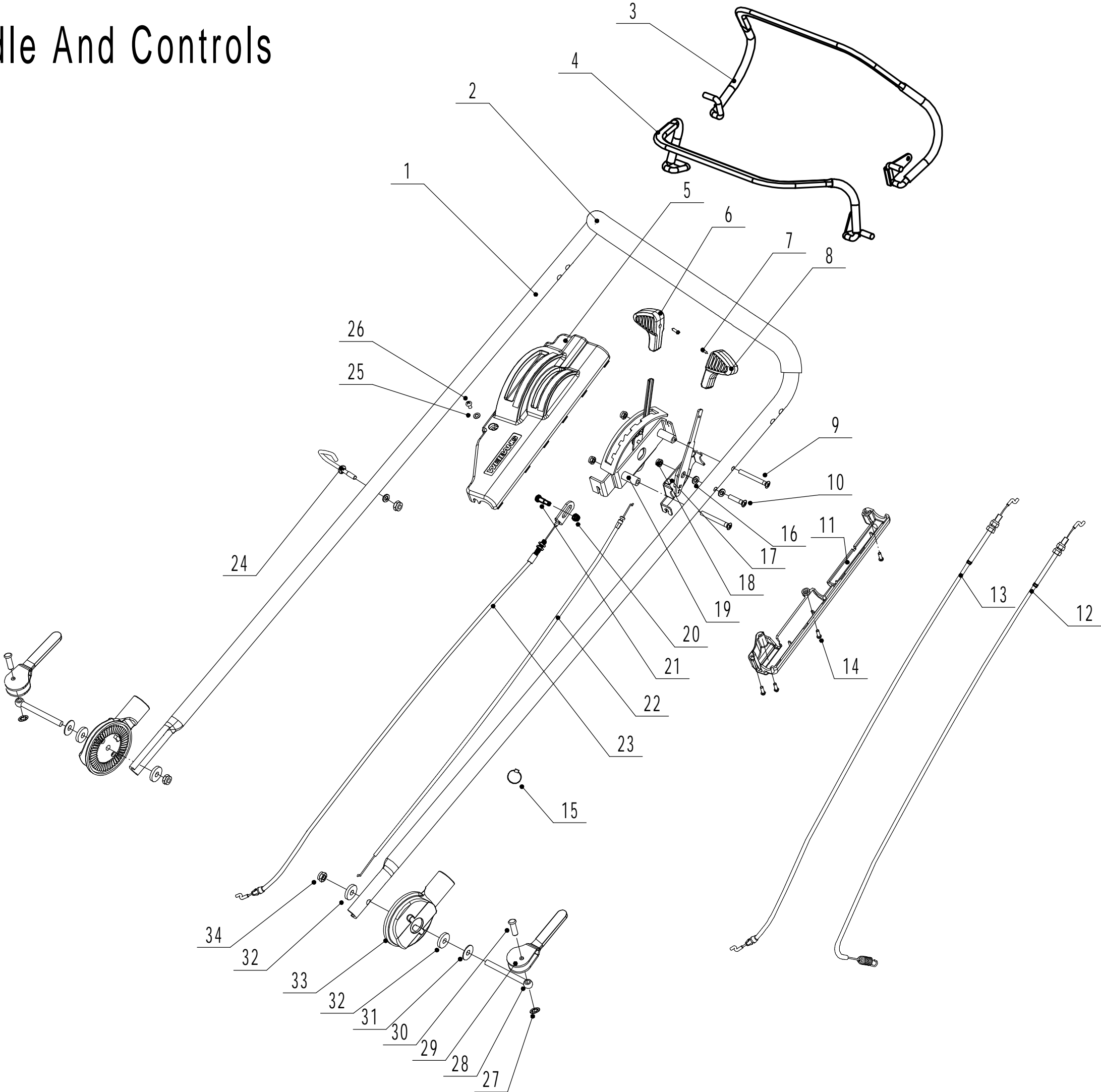

Ersatzteilliste Zeichnung Nummer 6		WB 486 SKL AL V		2019
Nummer	Ersatzteilnummer	Deutsche Bezeichnung	Englische Bezeichnung	Menge
1	5020501020S-49	Holm	Handle	1
2	GM56E010000080	Griffschutz	Handle Sheath	1
3	5320511030S-40	Kupplungshebel	Clutch Lever	1
4	5320503020S-40	Bremshebel	Brake Lever	1
5	5020501030S	Kabelboxhälfte	Control Box Cover	1
6	5380508010	Knopf	Speed Control Grip	1
7	0106003013	Schraube	Screw	2
8	5380510010	Knopf	Throttle Grip	1
9	0108006060	Schraube	Screw	2
10	0108006050	Schraube	Screw	1
11	5020501040S	Kabelboxhälfte	Control Box Lower Cover	1
12	LH186-1195	Bremskabel	Brake Cable	1
13	BS120-1140	Kupplungskabel	Clutch Cable	1
14	0113040018	Schraube	Screw	4
15	ZD3-190	Ring	Cable Tie	1
16	0301006000	Abstandshalter	Spacer	8
17	5380512010	Gashebel	Throttle Bracket	1
18	0202005000	Mutter	Lock Nut	1
19	5360505010K	Geschwindigkeitshebel	Speed Control Bracket	1
20	0202005000	Mutter	Lock Nut	1
21	5360506011	Bolzen	Speed Control Cable Bolt	1
22	YM82-1025-A	Gaszug	Throttle Cable	1
23	TX123-1055-B	Fahrgeschwindigkeitszug	Speed Control Cable	1
24	4510511010-01	Haken	Hook	1
25	0301005000	Scheibe	Flat Washer	1
26	0104005008	Schraube	Screw	1
27	4510114030	Kappe	Fix Cap	2
28	GM48S000000100	Bolzen	Connecting Bolt	2
29	GM56A100400000	Hebel	Lock Lever	2
30	0801008022	Stift	Axis Pin	2
31	GM56A100000040-04	Abstandshalter	Spacer	2
32	GM56A100000050-01	Scheibe	Spacer	4
33	GM48S030200000	Verstellsegment	Tooth Disc Kit	2
34	0201008000DD	Mutter	Lock Nut	2

# 7 Grasscatcher

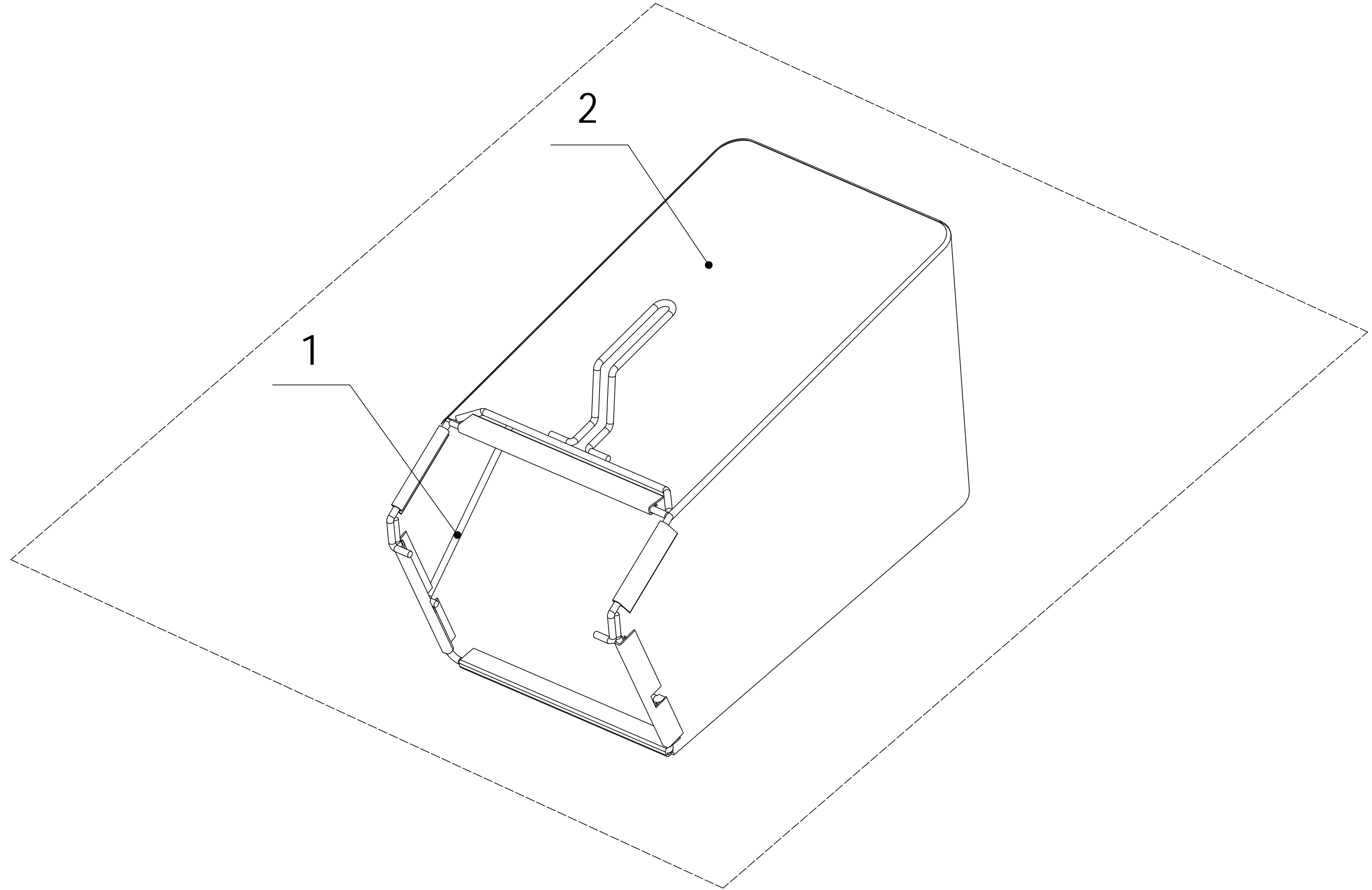

<b>Ersatzteilliste Zeichnung Nummer 7</b>		<b>WB 486 SKL AL V</b>		<b>2019</b>
<b>Nummer</b>	<b>Ersatzteilnummer</b>	<b>Deutsche Bezeichnung</b>	<b>Englische Bezeichnung</b>	<b>Menge</b>
1	4860602010S-22	Gestell	Grass Bag Frame	1
2	4820611010S-84	Fangsack	Grass Bag	1

# 8 Variable Speed Pulley

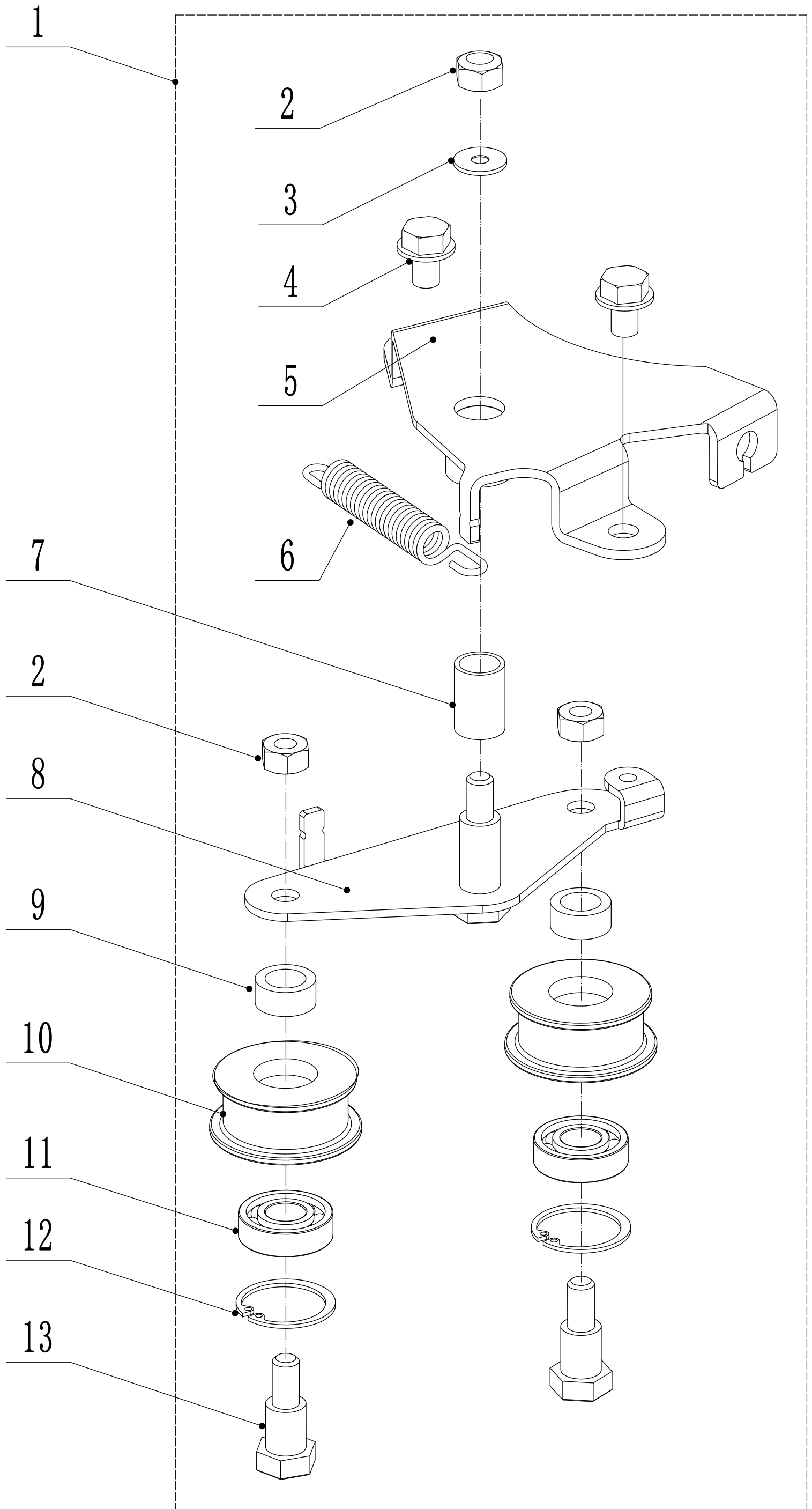

Ersatzteilliste Zeichnung Nummer 8		WB 486 SKL AL V		2019
Nummer	Ersatzteilnummer	Deutsche Bezeichnung	Englische Bezeichnung	Menge
1	Y094820	Spannarm	Belt Tensioner Assembly	1
2	0202008000	Mutter	Lock Nut	3
3	0302008000	Scheibe	Washer	1
4	4820113010	Schraube	Screw	2
5	4820109010-02	Halter	Tensional Arm Bracket	1
6	4820114010	Feder	Spring	1
7	4820112010	Buchse	Nylon Bush	1
8	4820115010-02	Platte	Tensional Arm Weldment	1
9	4820118010-02	Abstandshalter	Spacer	2
10	4820119010	Spannrolle	Tensional Pulley	2
11	6001-2RZ	Kugellager	Bearing	2
12	0901028000	Sicherungsring	Circlip	2
13	4820120010	Bolzen	Tensional Pulley Bolt	2