

2 Main Body

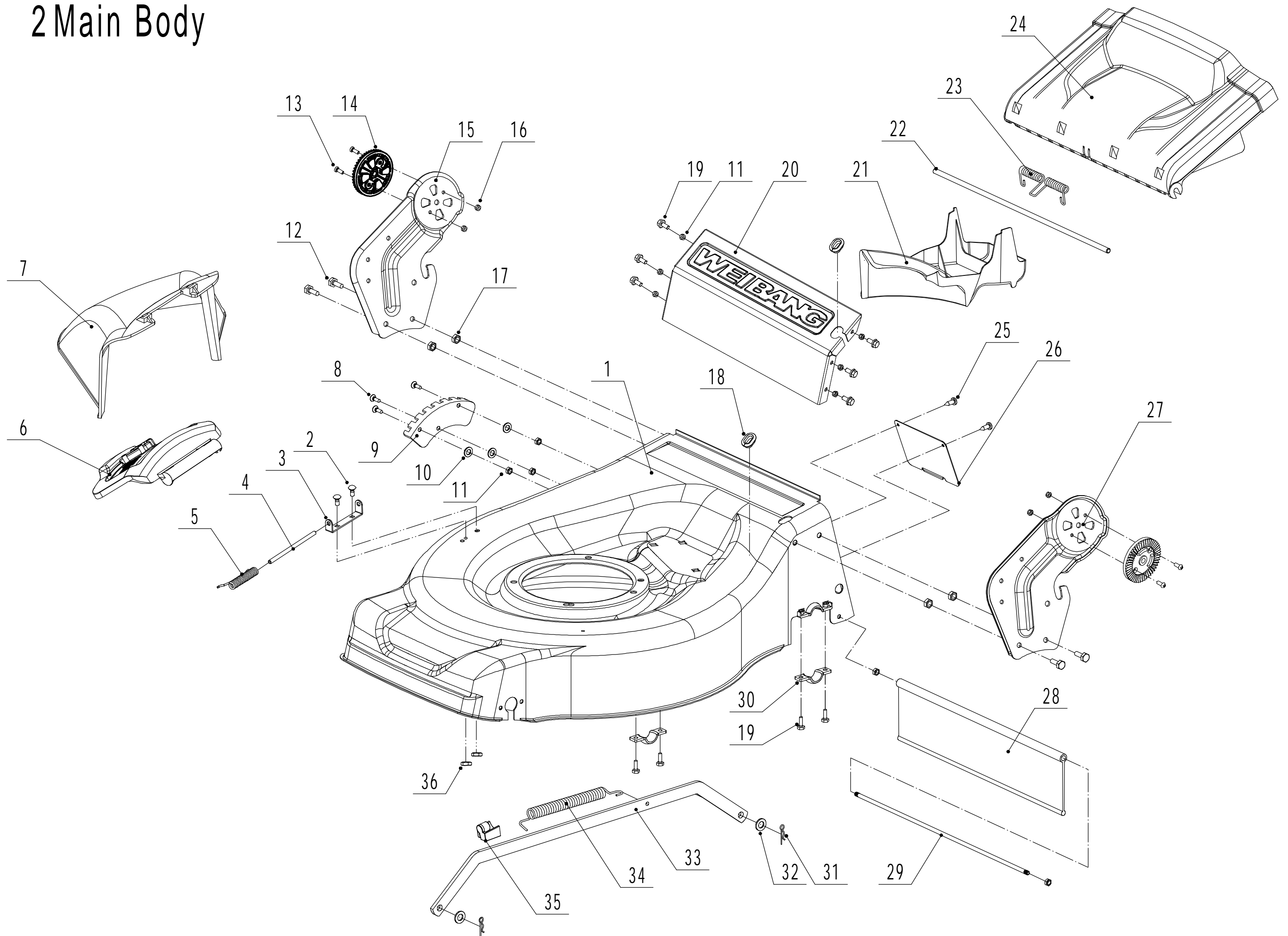

Ersatzteilliste Zeichnung Nummer 2		WB 536 SKL V 3-1		2019
Nummer	Ersatzteilnummer	Deutsche Bezeichnung	Englische Bezeichnung	Menge
1	5360101010J-49	Gehäuse	Chassis	1
2	0107006014	Bolzen	Bolt	2
3	5020118010-02	Halterung	Side Discharge Bracket	1
4	5020120010-02	Stange	Side Discharge Pivot	1
5	5020119010	Feder	Side Discharge Spring	1
6	5360119012	Verschlusskappe	Side Discharge Cover Kit	1
7	5360120010J	Seitenauswurf	Side Discharge Deflector	1
8	0104006016	Schraube	Screw	3
9	5360123010-01	Höheneinstellraste	Graduator	1
10	0301006000	Scheibe	Plain Washer	3
11	0202006000	Mutter	Lock Nut	9
12	0102008016	Bolzen	Bolt	4
13	0104005012	Schraube	Screw	4
14	AVSA000000040-22	Schnellverschluss	Tooth Disc	2
15	5360125010K-40	AVS Halter rechts	AVS Bracket R	1
16	0202005000	Mutter	Lock Nut	4
17	0202008000	Mutter	Lock Nut	4
18	5360122010C	Staubabdeckung	Rubber Ring	2
19	0102006012	Bolzen	Bolt	10
20	5360124030-49	Verbindungsstück	Connector	1
21	5360115010	Mulchstopfen	Mulching Plug	1
22	5360117010-02	Stange	Pivot- Rear Cover	1
23	5360118010	Feder	Spring- Rear Cover	1
24	5360116010	Abdeckung	Rear Cover	1
25	0106004009	Schraube	Screw	2
26	5360105010D-49	Blech	Baffle	1
27	5360124010K-40	AVS Halter links	AVS Bracket L	1
28	5360127010	Schutz	Trailing Flap	1
29	5360126010-02	Stange	Pivot- Trailing Flap	1
30	5320114020-01	Lagerhalter	Upper Bearing Bracket	2
31	5320333010	Federstift	Spring Clip	2
32	0301010000	Scheibe	Plain Washer	2
33	5360308010-40	Verbindungsstange	Connecting Rod	1
34	5320332010-01	Feder	Spring- Connecting Rod	1
35	4560109012	Federhalter	Spring Bracket	1
36	0204006000	Mutter	Lock Nut	2

3 Blade System

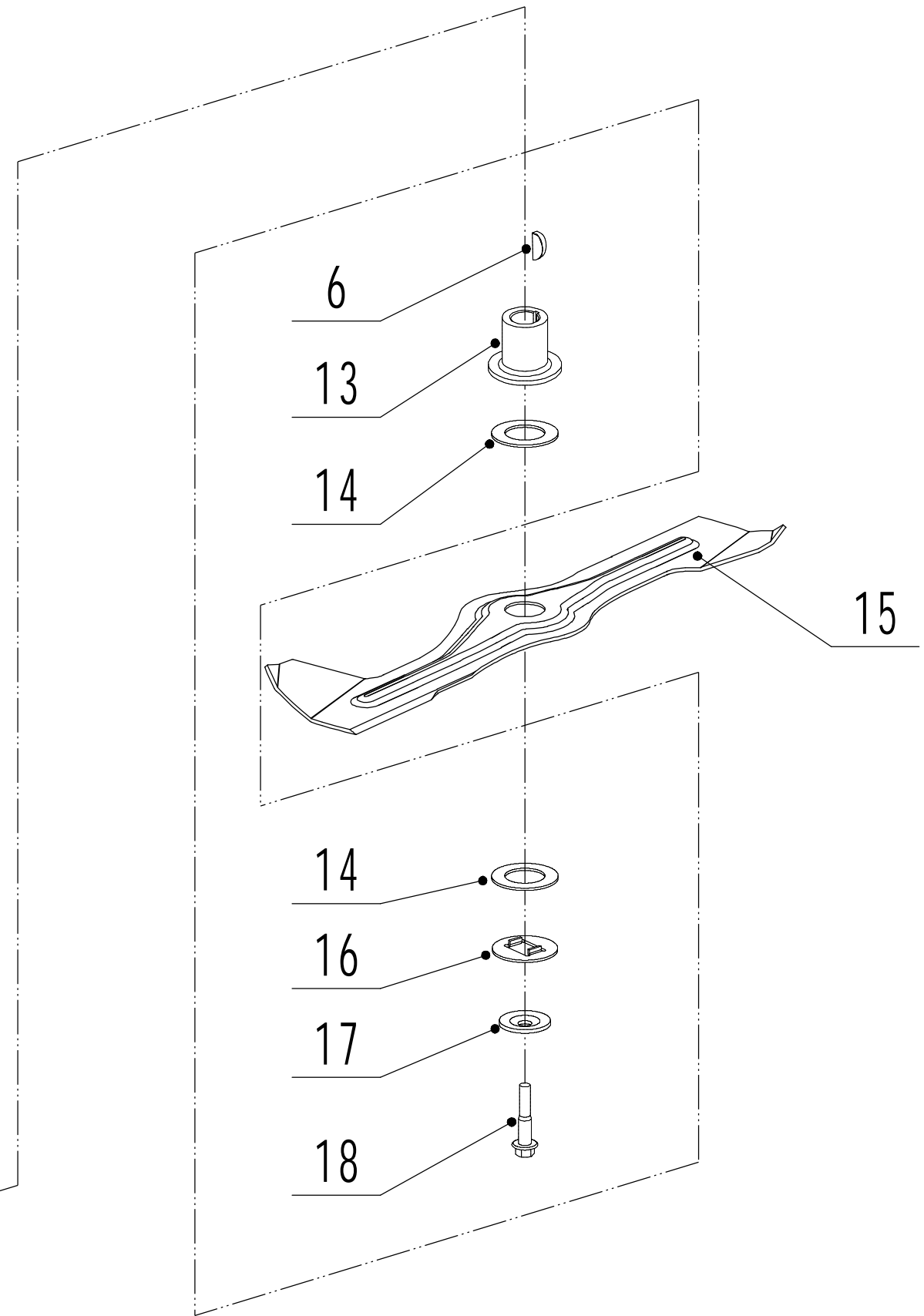
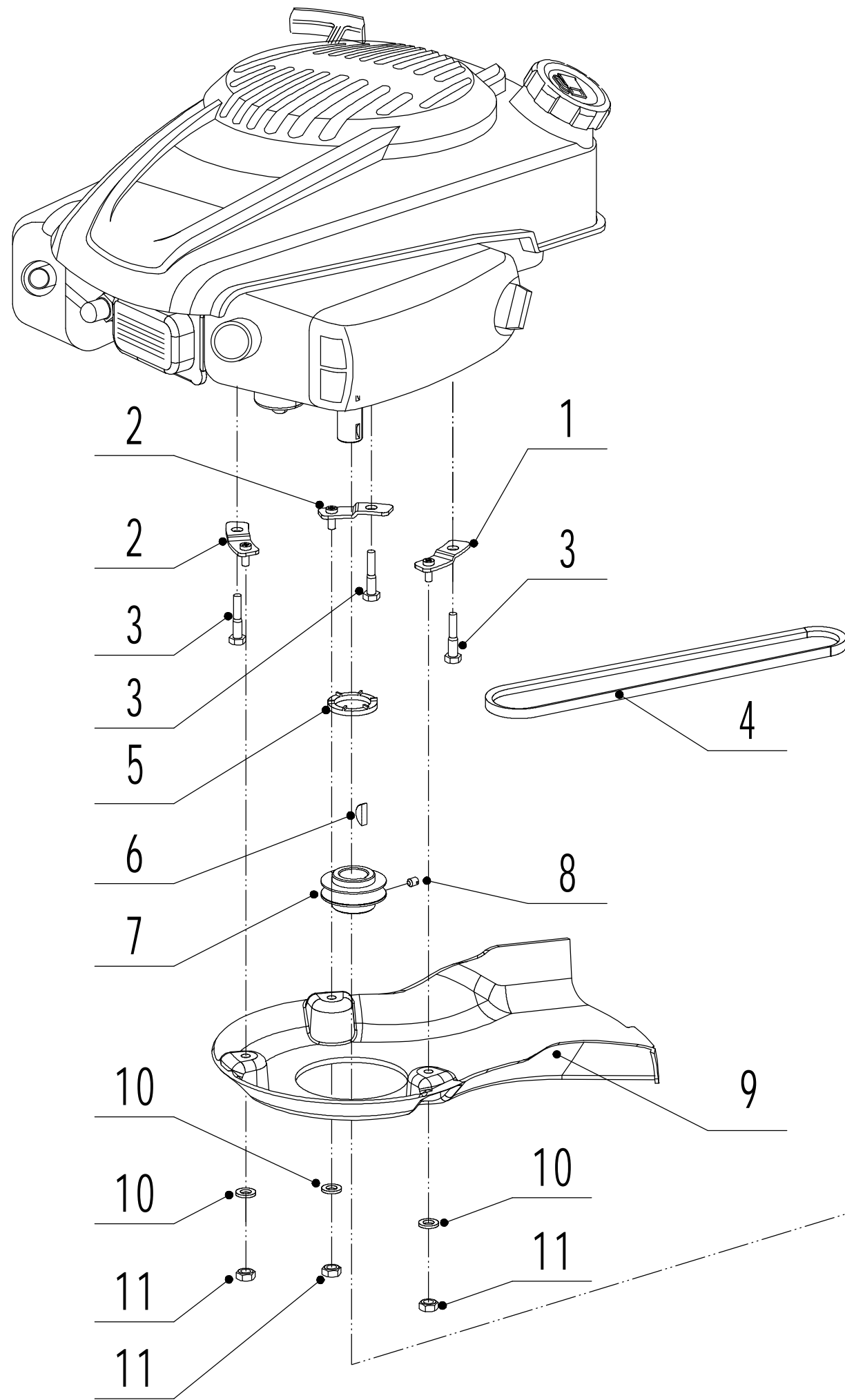

Ersatzteilliste Zeichnung Nummer 3		WB 536 SKL V 3-1		2019
Nummer	Ersatzteilnummer	Deutsche Bezeichnung	Englische Bezeichnung	Menge
1	5360111010-02	Unterlegscheibe	Engine Washer	1
2	5360112010-02	Unterlegscheibe	Engine Washer	2
3	5320115010	Schraube	Screw	3
4	5380113010S	Keilriemen	Belt	1
5	5360128030	Scheibe	Washer	1
6	5310401010	Keil	Key	2
7	5380402010	Riemenscheibe	Engine Pulley	1
8	0105006006	Sicherungsschraube	Lock Screw	1
9	5360113010	Riemenschutz	Beltshield	1
10	0302006000	Scheibe	Big Flat Washer	3
11	0202006000	Mutter	Lock Nut	3
13	5320404010-002	Messerhalter	Adaptor	1
14	5310402010	Friktionsscheibe	Friction Washer	2
15	5310403010A-22	Messer	Blade	1
16	5310404010-02	Ring	Locking Disc	1
17	5310406010-04	Federring	Spring Washer	1
18	5320405010	Messerschraube	Central Bolt	1

4 Front axle

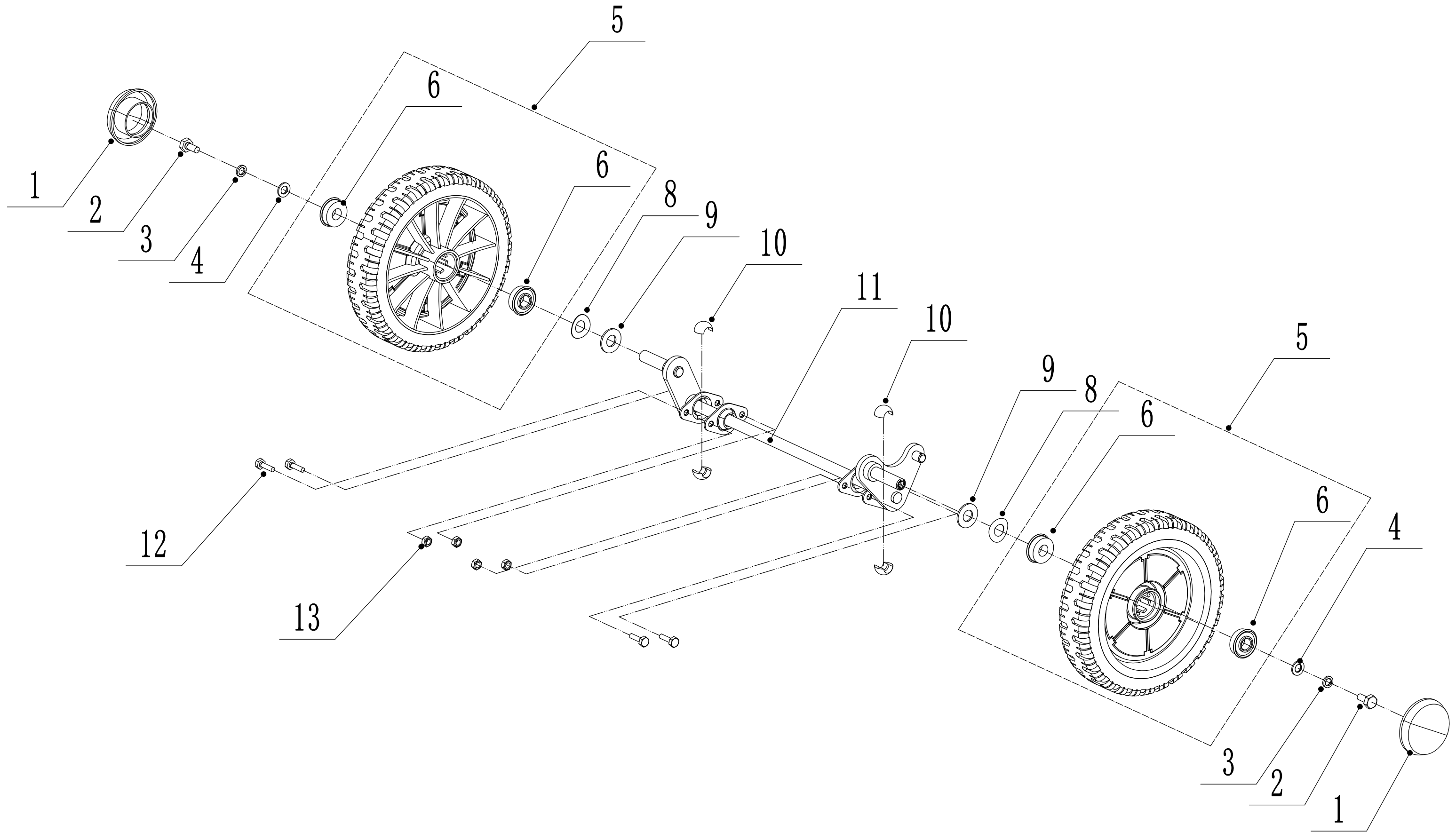

Ersatzteilliste Zeichnung Nummer 4		WB 536 SKL V 3-1		2019
Nummer	Ersatzteilnummer	Deutsche Bezeichnung	Englische Bezeichnung	Menge
1	5310214010	Radkappe	Wheel Cap	2
2	0101008015	Bolzen	Bolt	2
3	0401008000	Federscheibe	Spring Washer	2
4	0301006000	Scheibe	Washer	2
5	5310212010-40	Rad	Wheel	2
6	5310213010	Lager	Bearing	4
8	5310211010-02	Abstandshalter	Spacer	2
9	5310210010-02	Scheibe	Plain Washer	2
10	5310209010	Lager	Bearing	4
11	5360201010-01	Frontachse	Front Axle Welding	1
12	0102006016	Bolzen	Bolt	4
13	0202006000	Mutter	Lock Nut	4

5 Rear Axle

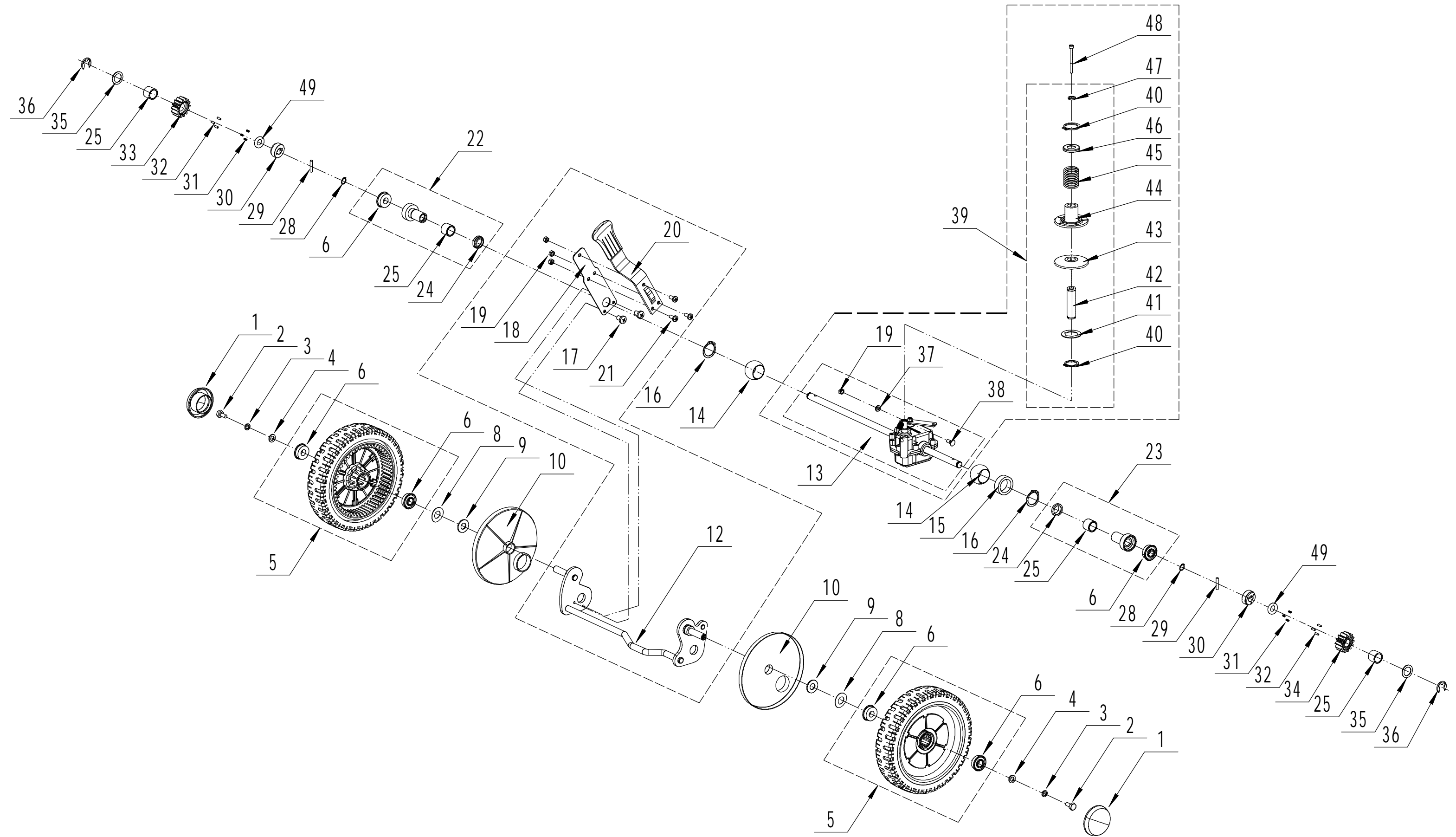

Ersatzteilliste Zeichnung Nummer 5		WB 536 SKL V 3-1		2019
Nummer	Ersatzteilnummer	Deutsche Bezeichnung	Englische Bezeichnung	Menge
1	5310214010	Radkappe	Wheel Cap	2
2	0101008015	Bolzen	Bolt	2
3	0401008000	Federscheibe	Spring Washer	2
4	0301006000	Scheibe	Washer	2
5	5340309010-40	Rad	Wheel	2
6	5310213010	Lager	Bearing	6
8	5310211010-02	Abstandshalter	Spacer	2
9	5310210010-02	Scheibe	Plain Washer	2
10	5340312010	Radabdeckung	Wheel Shield	2
12	5360301010-01	Hinterachse	Rear Axle Frame	1
13	Y20536V0P	Getriebe	Rear Transmission	1
14	5320328010	Nylon Lager	Nylon Ball Bearing	2
15	4520313010-02	Buchse	Rear Axle Partition	1
16	1001020000	Sicherungsring	Circlip	2
17	0104005008	Schraube	Screw	2
18	536031010-22	Halterung	Spring of Adj. Lever	1
19	0202006000	Mutter	Lock Nut	4
20	5360310010-40	Höheneinstellhebel	Ajustment Lever	1
21	0104006014	Schraube	Screw	3
22	Y065321	Lagerhalter rechts	Right Bearing Sheath	1
23	Y065320	Lagerhalter links	Left Bearing Sheath	1
24	5320327010	Staubschutz	Dust Seal	2
25	5320326010P	Lager	Bearing	4
28	1001012000	Sicherungsring	Circlip	2
29	HQ000100060	Stift	Pin	2
30	HQ000100050	Halter	One Way Block	2
31	HQ000100040	Feder	Spring	6
32	HQ000100030	Stift	Pin	6
33	HQ000100020	Zahnrad rechts	Right Drive Pinion	1
34	HQ000100010	Zahnrad links	Left Drive Pinion	1
35	5020311010-04	Scheibe	Washer	2
36	1301009000	Ring	E-Clip	2
37	0301006000	Scheibe	Plain Washer	1
38	0107006014	Bolzen	Bolt	1
39	Y115380	Riemenscheibe	Variable Speed Pulley	1
40	1001017000	Sicherungsring	Circlip	2
41	4820320010-02	Splint	Inner Hex Spacer	1
42	4820321010-02	Hülse	Hex Sleeve	1
43	5380309010	Scheibe	Lower Pulley Disc	1
44	5380308010	Variatorhälfte	Active Pulley Disc	1
45	4820324010	Druckfeder	Pressing Spring	1
46	4820325010-02	Sicherungsring	Circlip	1
47	0401005000	Federscheibe	Spring Washer	1
48	0103005055	Schraube	Screw	1
49	1401025015	Ring	O-Ring	2

6 Handle And Controls

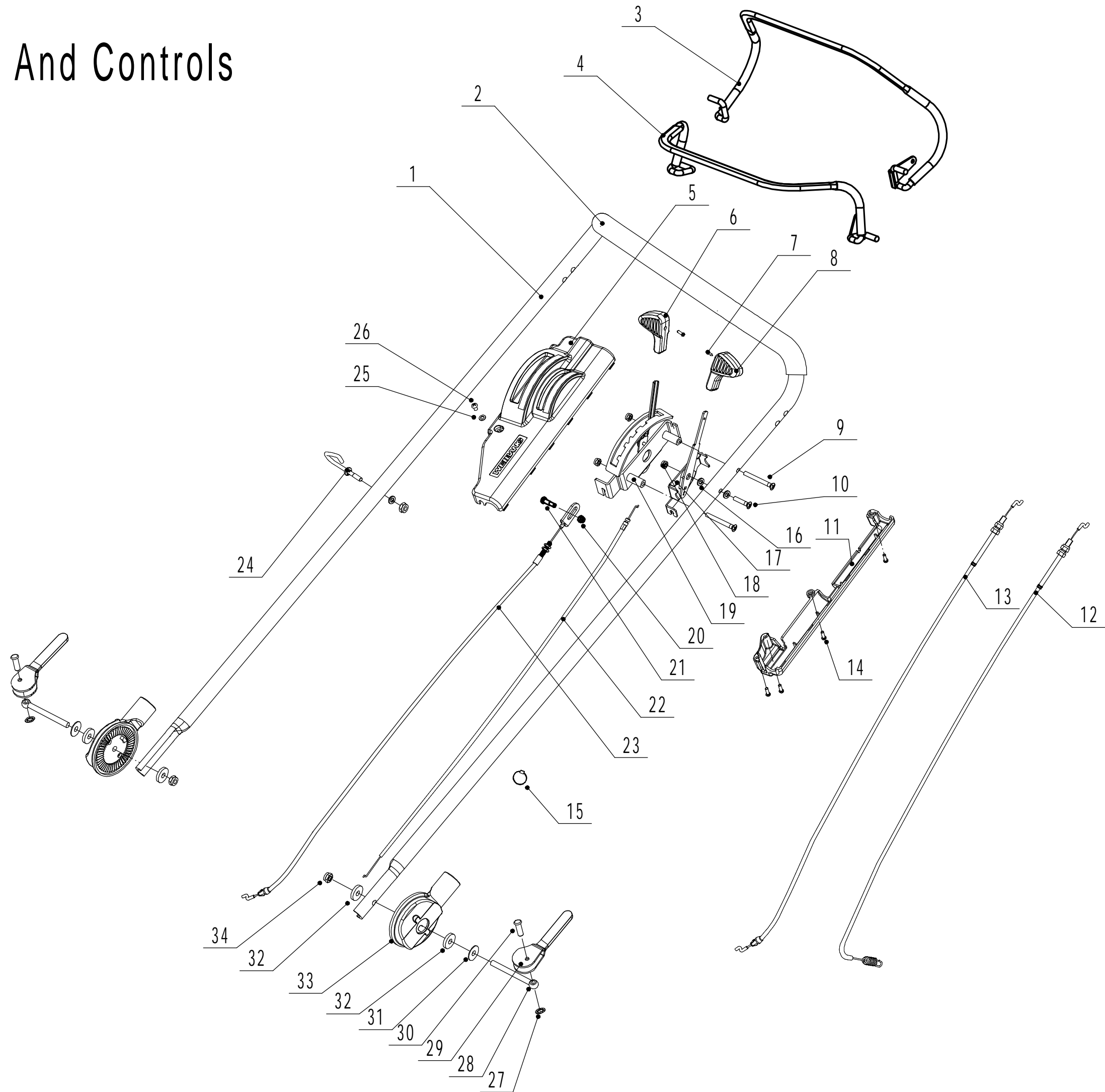

Ersatzteilliste Zeichnung Nummer 6		WB 536 SKL V 3-1		2019
Nummer	Ersatzteilnummer	Deutsche Bezeichnung	Englische Bezeichnung	Menge
1	GM53C01000001B-49	Holm	Handle	1
2	GM56E010000080	Gummischutz	Handle Sheath	1
3	5320511030S-40	Hebel	Clutch Lever	1
4	5320503020S-40	Hebel	OPC Lever	1
5	5020501030S	Kabelbox obere Hälfte	Control Cover	1
6	5380508010	Knopf	Speed Control Grip	1
7	0106003013	Schraube	Screw	2
8	5380510010	Gashebel	Throttle Control Grip	1
9	0108006060	Schraube	Screw	2
10	0108006050	Schraube	Screw	1
11	5020501040S	Kabelbox untere Hälfte	Control Box Lower Cover	1
12	LH186-1225	Kupplungskabel	Clutch Cable	1
13	BS120-1200	Motorbremskabel	OPC Cable	1
14	0113040018	Schraube	Screw	4
15	ZD3-190	Ring	Cable Tie	1
16	0301006000	Scheibe	Washer	7
17	5380512010	Hebel	Throttle Control Bracket	1
18	0202006000	Mutter	Lock Nut	4
19	5360505010K	Verstellsegment	Speed Control Bracket	1
20	0202005000	Mutter	Lock Nut	1
21	5360506011	Bolzen	Speed Control Cable Bolt	1
22	YM72-1115-A	Gaszug	Throttle Cable	1
23	TX130-1060-A	Fahrgeschwindigkeitszug	Speed Control Cable	1
24	4510511010-01	Haken	Hook- Starter Rope	1
25	0301005000	Scheibe	Washer	1
26	0104005008	Schraube	Screw	1
27	4510114030	Kappe	Fix Cap	2
28	GM48S000000100	Bolzen	Connecting Bolt	2
29	GM56A100400000	Hebel	Lock Lever	2
30	0801008022	Stift	Axis Pin	2
31	GM56A100000040-04	Abstandshalter	Spacer	2
32	GM56A100000050-01	Scheibe	Spacer	4
33	GM48S030200000	Verstellsegment	Tooth Disc Kit	2
34	0201008000DD	Mutter	Lock Nut	2

7 Grass Catcher

1

2

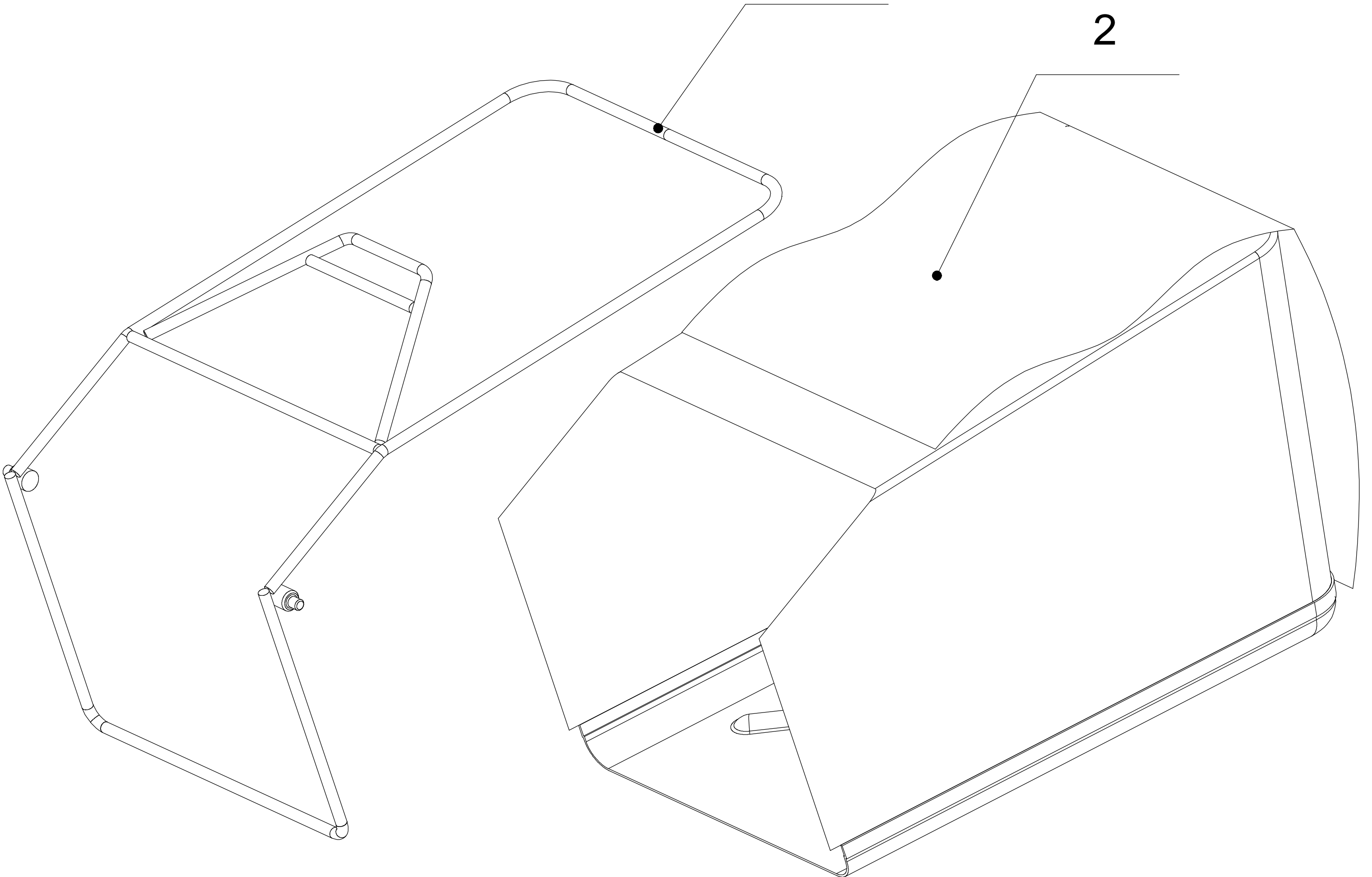

Ersatzteilliste Zeichnung Nummer 7		WB 536 SKL V 3-1		2019
Nummer	Ersatzteilnummer	Deutsche Bezeichnung	Englische Bezeichnung	Menge
1	5360602010T-22	Gestell	Grass Bag Frame	1
2	5360603010T-84	Fangsack	Grass Bag	1

8 Variable Speed Pulley

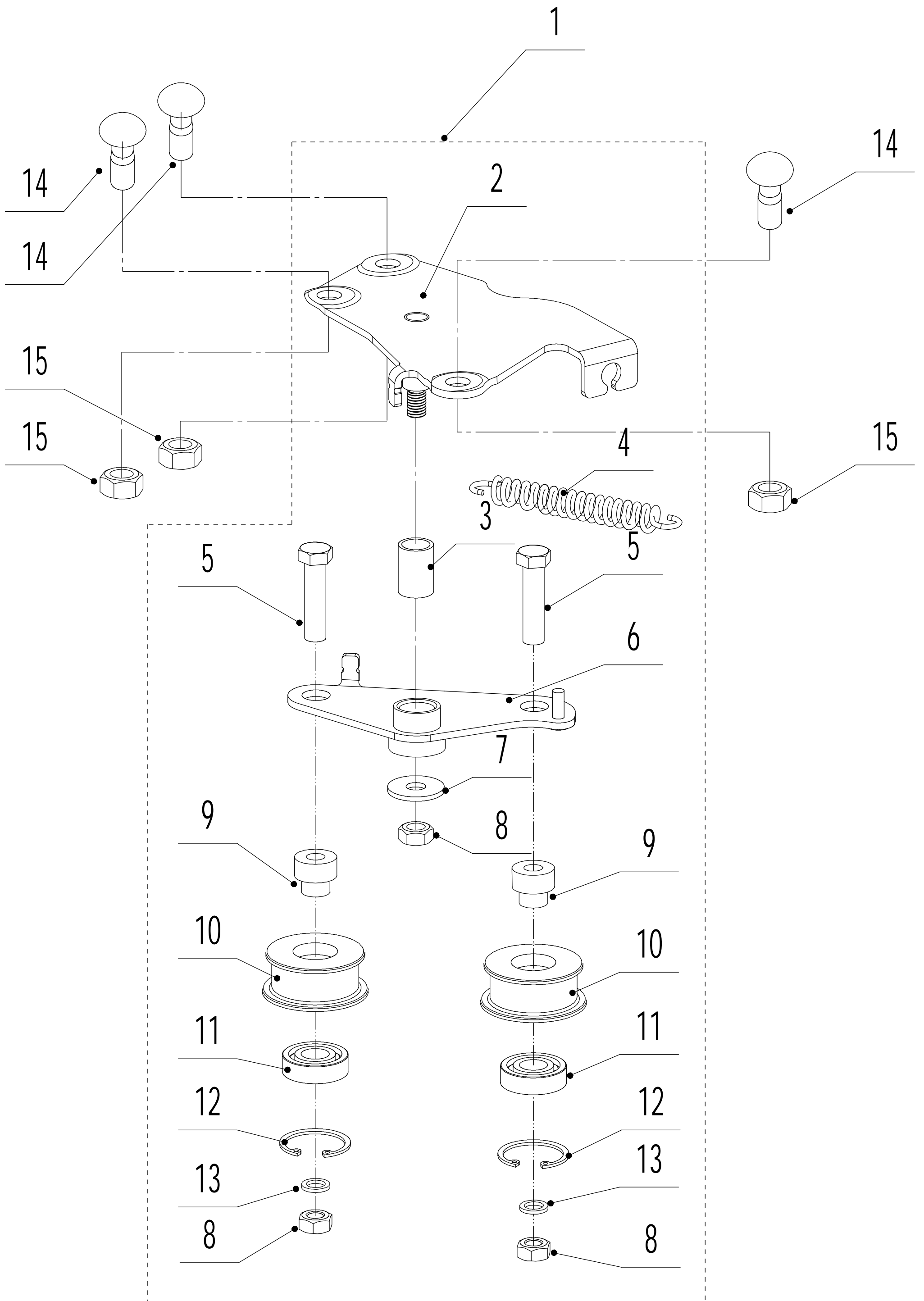

Ersatzteilliste Zeichnung Nummer 8		WB 536 SKL V 3-1		2019
Nummer	Ersatzteilnummer	Deutsche Bezeichnung	Englische Bezeichnung	Menge
1	Y095360	Spannarm	Belt Tension Assembly	1
2	5360129010-02	Halter	Tensional Arm Bracket	1
3	4820112010	Buchse	Nylon Bush	1
4	4820114010	Feder	Tensional Spring	1
5	4820120010	Bolzen	Tensional Pulley Bolt	2
6	5360130010-02	Spannarm	Tensional Arm Weldment	1
7	0302008000	Scheibe	Washer	1
8	0202008000	Mutter	Lock Nut	3
9	5360131020-02	Hülse	Tensional Pulley Partition	2
10	4820119010	Riemenscheibe	Tensional Pulley	2
11	6001-2RZ	Lager	Bearing	2
12	0901028000	Sicherungsring	Internal Circlip	2
13	0301008000	Scheibe	Plain Washer	2
14	0107010025	Bolzen	Bolt	3
15	0202010000	Mutter	Lock Nut	3